

**CITY COUNCIL MEETING  
AGENDA**

**March 4, 2026  
7:00 PM  
Civic Center**

The Granite Falls City Council will hold its meeting in person. A Zoom link may be requested by contacting the City Clerk at [darla.wilkins@ci.granite-falls.wa.us](mailto:darla.wilkins@ci.granite-falls.wa.us), no later than 3:00 p.m. on the day of the meeting. Virtual access is provided for listening purposes only. Public comment will not be accepted via Zoom. City residents who wish to provide a comment may email the City Clerk with their name, address, and the message they would like read into the record.

---

- 1. CALL TO ORDER**
- 2. FLAG SALUTE**
- 3. ROLL CALL**
- 4. CONSENT AGENDA**
  - 4.a. AB 038-2026 Approval of February 18, 2026 Minutes**
  - 4.b. AB 039-2026 Approval of March 4, 2026 Claims Checks #416015 through 416062 totaling \$137,147.06**
  - 4.c. AB 040-2026 Approval of February 1, 2026 through February 15, 2026 Payroll Claims Checks consisting of Twenty-Two EFT's totaling \$95,647.02**
- 5. STAFF REPORTS**
  - 5.a. Passports**
  - 5.b. Planning**
  - 5.c. City Clerk**
  - 5.d. Public Works**
  - 5.e. Police**
- 6. PUBLIC COMMENTS/RECOGNITION OF VISITORS-NON-ACTION ITEMS**

(The public is encouraged to submit written comments prior to the meeting by emailing them directly to the city clerk at: [darla.wilkins@ci.granite-falls.wa.us](mailto:darla.wilkins@ci.granite-falls.wa.us); and should be submitted no later than 5PM. Public comment speakers can sign up prior to the meeting, or wait for the public comment section of the meeting to be open by the presiding officer. Individual comments shall be limited to three minutes. Group comments shall be limited to five minutes).

**7. NEW BUSINESS**

**7.a. AB 041-2026 Capitol Path Update**

**7.b. AB 042-2026 UW Student Mid-term Presentation on Hazard Mitigation Plan**

**7.c. AB 043-2026 Discussion - Update SB 6002 - Driver Privacy Protections and ALPR Program Compliance**

**7.d. AB 044-2026 Discussion - City Council Size Expansion Options**

**7.e. AB 045-2026 Consideration to Reactivate the Salary Commission and Review the City Council Compensation**

**7.f. AB 046-2026 Legion Park – Proposed Park Layouts, Monument Design, and Feature Options (Discussion Only)**

**8. CURRENT BUSINESS**

**9. MAYOR'S COMMENT (5 MINUTES)**

**10. COUNCIL COMMENTS (15 MINUTES)**

**11. CITY MANAGER (5 MINUTES)**

**12. ADJOURNMENT**

The City of Granite Falls strives to provide access and services to all members of the public.



CITY OF  
GRANITE FALLS

## CITY COUNCIL AGENDA BILL

**Subject:** 4.a.

**Originating Dept.:** City Clerk

**Action Recommended:** Approval of  
Consent Agenda

**Approval(s):** City Clerk  
City Manager

**Meeting Date:** March 4, 2026

**Date Submitted:**

**Exhibit(s):**

1. 02-18-2026 Minutes
- 

**Budgeted Amount:**

**BARS Code:**

---

**Summary Statement:**

The city council minutes are the official action taken and direction given at the meetings of the city council. Any councilmember may remove item(s) from the consent agenda for discussion and the item(s) would be voted on separately from the other consent agenda items.

---

**Background:**

---

**Recommended Motion:**

- 1) Motion to approve the minutes as shown. This can be accomplished as part of the motion to approve the consent agenda.
- 2) Motion to amend the [state date] minutes and approve the minutes as amended.



**CITY COUNCIL MEETING  
MINUTES**

**February 18, 2026  
7:00 PM  
Civic Center**

City Council	Councilmember Steven Glenn, Councilmember David Griggs, Councilmember Tom FitzGerald, Councilmember Bruce Straughn
City Staff	City Clerk Darla Wilkins, City Manager Jeff Balentine, Deputy City Manager Brent Kirk, Public Works Director Charles White, Planning Director Amy Hess, Deputy City Clerk Carole Williams
Consultants	Consultant Police Chief Tom Dalton, Consultant City Attorney Emily Guildner

**1. CALL TO ORDER**

**Mayor Pro Tem David Griggs** called the City Council Meeting to order at 7:00 p.m.

**2. FLAG SALUTE**

**Mayor Pro Tem David Griggs** led the Council, Staff and Audience in the Pledge of Allegiance to the flag.

**3. ROLL CALL**

**City Clerk Darla Wilkins** verbally called out the Council's names and took note of the meeting attendance.

<b>MOTION:</b>	Motion to excuse Mayor Hartman for personal reasons.
<b>MOVER:</b>	Mayor Pro Tem/City Councilmember David Griggs
<b>SECONDER:</b>	City Councilmember Steven Glenn

<b>AYES:</b>	City Councilmember Tom FitzGerald, City Councilmember Steven Glenn, Mayor Pro Tem/City Councilmember David Griggs, City Councilmember Bruce Straughn
<b>NAYS:</b>	None
<b>RESULT:</b>	<b>Passed</b>

**4. CONSENT AGENDA**

**City Clerk Darla Wilkins** asked the Council to consider approving the minutes that were emailed out yesterday for the meeting dates of January 14, 2026, February 4, 2026, and February 11, 2026.

<b>MOTION:</b>	Motion to add the January 14, 2026, February 4, 2026 and February 11, 2026 meeting minutes to the consent agenda.
<b>MOVER:</b>	City Councilmember Bruce Straughn
<b>SECONDER:</b>	City Councilmember Tom FitzGerald
<b>AYES:</b>	City Councilmember Tom FitzGerald, City Councilmember Steven Glenn, Mayor Pro Tem/City Councilmember David Griggs, City Councilmember Bruce Straughn
<b>NAYS:</b>	None
<b>RESULT:</b>	<b>Passed</b>

<b>MOTION:</b>	Motion to approve the consent agenda.
<b>MOVER:</b>	City Councilmember Bruce Straughn
<b>SECONDER:</b>	City Councilmember Steven Glenn
<b>AYES:</b>	City Councilmember Tom FitzGerald, City Councilmember Steven Glenn, Mayor Pro Tem/City Councilmember David Griggs, City Councilmember Bruce Straughn
<b>NAYS:</b>	None
<b>RESULT:</b>	<b>Passed</b>

**4.a. AB 031-2026 Approval of January 21, 2026 Minutes**

**4.b. AB 032-2026 Approval of February 18, 2026 Claims Checks #415980 through 416010 totaling \$418,671.36**

- 4.c. **AB 033-2026 Approval of January 16, 2026 through January 31, 2026 Payroll Claims Checks #415933 through 415935 and Twenty-Seven EFT's totaling \$170,608.47**

**5. STAFF REPORTS**

**5.a. Public Works**

**Public Works Director Charles White** commented on the following:

- Pothole patching on Menzel Lake Rd.
- Jetting on Leola Lane
- WFI for Dept. of Health has been submitted
- Trees removed at Perrigoue Ballfields
- Working on old Fire Station
- Burn for Legion moved to March 11th
- Snow plowing

**5.b. City Clerk**

**City Clerk Darla Wilkins** had nothing additional to add to her report. However, she did mention that Deputy City Clerk Carole Williams had recently attended a Springbrook conference/training last week and asked her to highlight some of the things she learned.

**Deputy City Clerk Carole Williams** thanked the Council & Staff for the opportunity to attend the training and mentioned what the conference was for.

**5.c. Planning**

**Planning Director Amy Hess** commented on the following:

- Go live date 4/21 (Smart Gov Software)
- Moonbird Crossing (complete application)

**5.d. Passports**

**City Manager Jeff Balentine** gave a brief financial update on the passport office.

**5.e. Consultant Police Chief**

**Consultant Police Chief Tom Dalton** commented on the following:

- Staff Training
- SnoCo Alerts

- Coffee with the Chief (Saturday)
- Snohomish County Chief's & Sheriff's Meeting
- Deputy Nunemaker (recognized by the American Legion)

**6. PUBLIC COMMENTS/RECOGNITION OF VISITORS-NON-ACTION ITEMS**

None.

**7. NEW BUSINESS**

**7.a. AB 034-2026 Public Hearing 7:10 PM or soon thereafter to Consider to approval of Resolution 2026-04, adopting the Parks Recreation and Open Space (PROS) Plan**

<b>MOTION:</b>	Motion to open the public hearing.
<b>MOVER:</b>	City Councilmember Steven Glenn
<b>SECONDER:</b>	City Councilmember Bruce Straughn
<b>AYES:</b>	City Councilmember Tom FitzGerald, City Councilmember Steven Glenn, Mayor Pro Tem/City Councilmember David Griggs, City Councilmember Bruce Straughn
<b>NAYS:</b>	None
<b>RESULT:</b>	<b>Passed</b>

**Public Works Director Amy Hess** commented on the proposal, and included the Mayor's stating his verbal support of the plan.

**Consultant Planner Eric Jensen, EJ Municipal Land Use Planning**, gave a slideshow presentation and spoke in detail about the following items:

- Purpose of the Plan
- Content of the PROS Plan
- RCO Eligibility
- Capital Improvement Planning
- Next Steps

Council suggested changes/discussion items:

- Errors on the facility forms (need corrected)

**Mayor Pro Tem David Griggs** opened the public testimony portion of the public hearing.

No one signed up or chose to comment.

**Mayor Pro Tem David Griggs** closed the public testimony portion of the public hearing.

<b>MOTION:</b>	Motion to close the public hearing.
<b>MOVER:</b>	City Councilmember Bruce Straughn
<b>SECONDER:</b>	City Councilmember Tom FitzGerald
<b>AYES:</b>	City Councilmember Tom FitzGerald, City Councilmember Steven Glenn, Mayor Pro Tem/City Councilmember David Griggs, City Councilmember Bruce Straughn
<b>NAYS:</b>	None
<b>RESULT:</b>	<b>Passed</b>

<b>MOTION:</b>	Motion to approve Resolution 2026-04, a Resolution of the City Council of the City of Granite Falls, Washington, adopting the 2026 Parks, Recreation and Open Space Plan with the following revision; specifically allowing staff to update Appendix G - Facility Assessment Survey as warranted over time, and authorize the Mayor Pro Tem to sign.
<b>MOVER:</b>	City Councilmember Bruce Straughn
<b>SECONDER:</b>	City Councilmember Steven Glenn
<b>AYES:</b>	City Councilmember Tom FitzGerald, City Councilmember Steven Glenn, Mayor Pro Tem/City Councilmember David Griggs, City Councilmember Bruce Straughn
<b>NAYS:</b>	None
<b>RESULT:</b>	<b>Passed</b>

**7.b. AB 035-2026 Approval of Personnel Policies and Procedures Employee Handbook**

**City Manager Jeff Balentine** discussed the Personnel Policies & Procedures Handbook. The presentation included the following highlights:

- Presentation Overview
- Purpose and Scope
- Important Notice to Employees
- Our Guiding Principals
- Equal Employment Opportunity
- Reasonable Accommodation

- Employment Classifications
- Compensation and Hours
- Pay Transparency and Employee Rights
- Rest and Meal Breaks
- Paid Sick Leave (RCW 49.46)
- Vacation Leave Accrual
- Holiday Pay
- Family and Medical Leave Programs
- Additional Leave Benefits
- Health and Retirement Benefits
- Standards of Conduct
- Workplace Safety and Health
- Performance Management
- Progressive Discipline Process
- Grievance and Appeal Procedures
- Implementation Plan
- Fiscal and Legal Considerations
- Questions & Discussion

City Council and Staff discussed thoughts and ideas on the handbook. It was agreed upon that no action would be taken on this item tonight.

**7.c. AB 036-2026 Approval of Purchasing Procedures Manual**

**City Manager Jeff Balentine** discussed the Purchasing Procedure Manual through the use of a PowerPoint presentation that included the following slides:

- Presentation Overview
- Purpose and Scope
- Guiding Principles
- Key Legal Authority
- City Manager Purchasing Authority
- Department Head Authority
- City Council Retained Authority
- Non Public Works Under \$35,000
- Non Public Works \$35,000-\$40,000
- Non Public Works over \$40,000
- Public Works Contracting Thresholds
- Prevailing Wage Requirements
- Limited Public Works
- Small Works Roster Administration
- Small Works Roster Process Cycle
- Formal/Sealed Bidding

- Professional and Consulting Services
- Emergency Purchases
- Sole-Source Purchases
- Cooperative Purchasing (RCW 39.34)
- Documentation and Records
- City Manager Reporting Requirements
- Responsibilities and Controls
- Common Purchasing Mistakes
- Quick Reference Summary (2026)
- Implementation Plan

Councilmembers expressed their concerns and discussion ensued.

<b>MOTION:</b>	Motion to approve the City of Granite Falls' Purchasing Procedures Manual and authorizing the City Manager to make administrative updates as required by changes in federal, state, or local law, or to correct technical or clerical errors.
<b>MOVER:</b>	City Councilmember Tom FitzGerald
<b>SECONDER:</b>	City Councilmember Bruce Straughn
<b>AYES:</b>	City Councilmember Tom FitzGerald, City Councilmember Steven Glenn, Mayor Pro Tem/City Councilmember David Griggs, City Councilmember Bruce Straughn
<b>NAYS:</b>	None
<b>RESULT:</b>	<b>Passed</b>

**7.d. AB 037-2026 Selection of DEM Advisory Board Representative**

<b>MOTION:</b>	Motion to appoint Councilmember Tom FitzGerald as the City of Granite Falls representative to the DEM Advisory Board, and City Manager Jeff Balentine as the alternate representative, to serve until successor appointments are made or until further action of the City Council.
<b>MOVER:</b>	Mayor Pro Tem/City Councilmember David Griggs
<b>SECONDER:</b>	City Councilmember Tom FitzGerald
<b>AYES:</b>	City Councilmember Tom FitzGerald, City Councilmember Steven Glenn, Mayor Pro Tem/City Councilmember David Griggs, City Councilmember Bruce Straughn
<b>NAYS:</b>	None

<b>RESULT:</b>	<b>Passed</b>
----------------	---------------

**8. CURRENT BUSINESS**

None.

**9. MAYOR'S COMMENT (5 MINUTES)**

**Mayor Pro Tem David Griggs** commented on the following:

- Coffee with the Chief Meeting
- Legion burn & future plans for memorial
- Formal discussion on appointment of additional councilmembers

**10. COUNCIL COMMENTS (15 MINUTES)**

**Councilmember Tom FitzGerald** commented on the following:

- Pothole on Wabash
- Wants to have a council retreat to go around and check out other City's parks and collect ideas
- Girls high school basketball - playoffs

**Councilmember Bruce Straughn** commented on the following:

- Thoughts on having city staff reach out to other City's and ask them what their gem of a park is and then have staff take pictures of their responses

**Councilmember Steven Glenn** commented on the following:

- Listened to a passport & Legion burn discussion while shopping at the Granite Falls Shell station this morning
- Saw people staged ready to take pictures and watch the Legion building get burned although it got cancelled
- Nice to see the roads were cleared (snow)

**11. CITY MANAGER (5 MINUTES)**

**City Manager Jeff Balentine** commented on the following:

- Thanked Mohanna Goravanchi for helping get our 2025 Annual Report completed
- Flock policy = County draft policy
- State Bill 6002 passed the Senate today
- Public Works = great job on snow removal
- Community center and Legion Park (making good progress)
- Will review Legion Park (March 4th) concept design with Priceless Granite

- March 11th - work session meeting will be held at the old fire station
- AWC Conference (let Darla or Jeff know if you want to attend)
- Boys & Girls Club Teen Center - Grand Opening (attended)

## **12. ADJOURNMENT**

With no further business to come before the Council, the meeting was adjourned at 9:08 p.m.

---

City Clerk Darla Wilkins, MMC

---

Mayor Matthew Hartman



## CITY COUNCIL AGENDA BILL

**Subject:** 4.b.

**Originating Dept.:** City Manager

**Action Recommended:** Approval of Consent Agenda

**Approval(s):** City Manager  
Finance

**Meeting Date:** March 4, 2026

**Date Submitted:**

**Exhibit(s):** None

---

**Budgeted Amount:** \$137,147.06

**BARS Code:** 001 Current Expense = \$73,134.42

101 Streets = \$5,065.96

401 Water = \$31,201.05

403 Sewer = \$21,376.24

405 Storm Drainage = \$4,248.69

630 Trust Agency = \$2,120.70

---

**Summary Statement:**

March 4, 2026 Claims are for the time period of February 19, 2026 through March 4, 2026.

---

**Background:**

---

**Recommended Motion:**

- 1) Motion to approve the claims as presented. This can be accomplished as part of the motion to approve the consent agenda.
- 2) Motion to amend the [state date] claims and approve the minutes as amended.



## CITY COUNCIL AGENDA BILL

**Subject:** 4.c.

**Originating Dept.:** City Manager

**Action Recommended:** Approval of  
Consent Agenda

**Approval(s):** Finance  
City Manager

**Meeting Date:** March 4, 2026

**Date Submitted:**

**Exhibit(s):** None

---

**Budgeted Amount:** \$95,647.02  
**BARS Code:** 001 Current Expense = \$34,219.07  
101 Streets = \$9,011.27  
401 Water = \$17,986.82  
403 Sewer = \$29,627.93  
405 Storm Drainage = \$4,801.93

---

### **Summary Statement:**

Payroll claims are for February 1, 2026 through February 15, 2026

---

### **Background:**

---

### **Recommended Motion:**

- 1) Motion to approve the claims as presented. This can be accomplished as part of the motion to approve the consent agenda.
- 2) Motion to amend the [state date] claims and approve the minutes as amended.



CITY OF  
GRANITE FALLS

**CITY COUNCIL AGENDA BILL**

**Subject:** 5.a.

**Originating Dept.:** City Council

**Action Recommended:**

**Approval(s):**

**Meeting Date:** March 4, 2026

**Date Submitted:**

**Exhibit(s):**

1. COGF Passport PnL

---

**Budgeted Amount:**

**BARS Code:**

---

**Summary Statement:**

---

**Background:**

---

**Recommended Motion:**

As of February 22, 2026

### 30-day Statistics By Day

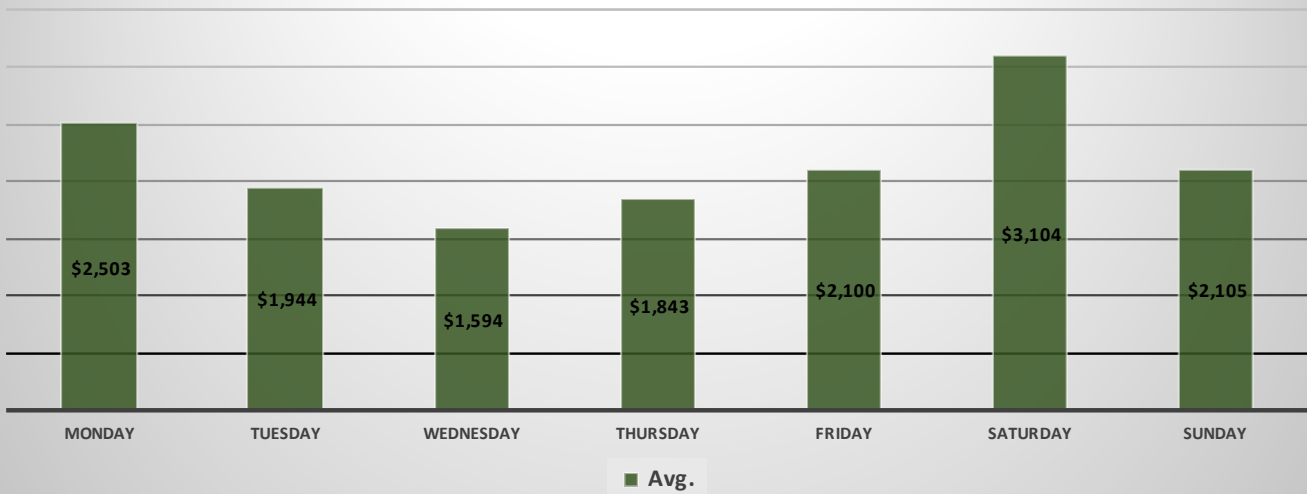

### 30-day Application & Photo Processing By Weekday

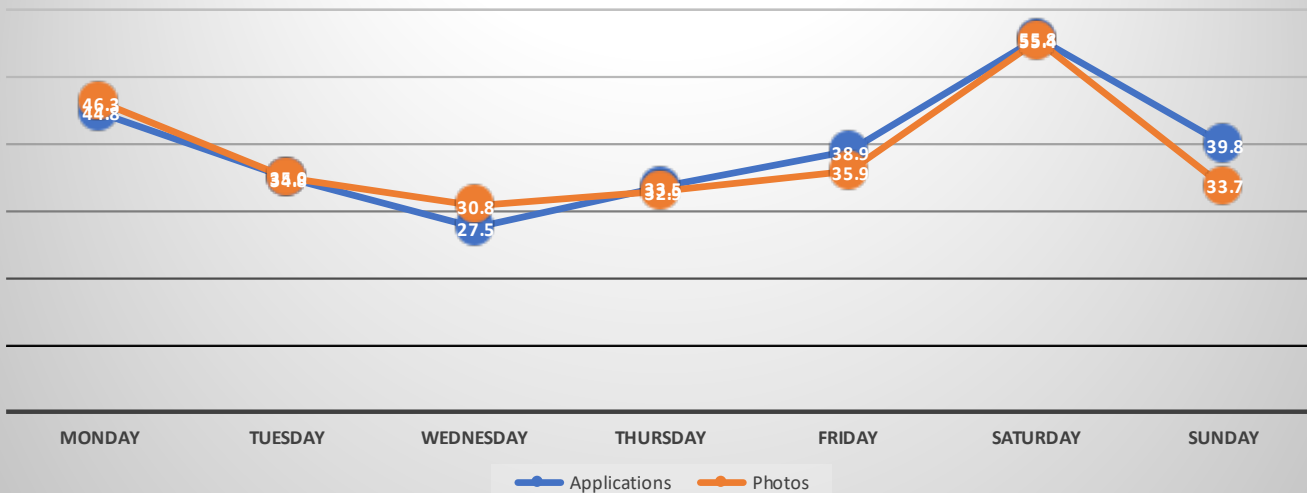

	Revenue since 6-6-2022	Revenue YTD 2026	Gross Margin YTD 2026	
Total Revenue (since 6-6-2022)	\$ 1,232,352.35	\$ 110,409.00	\$ 62,581.35	
30-day Annualized Revenue Trend	\$ 760,363.87		56.7%	
	Gross Margin	% Sales	Tracking v Budget	Revenue Change v prior year
Total Gross Margin (since 6-6-2022)	\$ 547,169.43	44.4%	\$ 6,405.60	\$ (27,446.60)
30-day Annual Projected Gross Margin	\$ 430,984.76	56.7%	6.7%	-19.9%
		# Processed	Last 30 day Avg. per day	Break Even
Total Passport Applications Processed		37,674	39.9	15.7
Total Passport Photos Taken		34,508	39.0	14.4



CITY OF  
GRANITE FALLS

## CITY COUNCIL AGENDA BILL

**Subject:** 5.b.

**Originating Dept.:** Planning Department

**Action Recommended:**

**Approval(s):**

**Meeting Date:** March 4, 2026

**Date Submitted:**

**Exhibit(s):**

1. 03.04.2026 Planning Staff Report

---

**Budgeted Amount:**

**BARS Code:**

---

**Summary Statement:**

---

**Background:**

---

**Recommended Motion:**



## CITY COUNCIL STAFF REPORT

**To:** Mayor and City Council

**From:** Amy Hess, Planning Director

**Department:** Planning and Community Development

**Date:** March 4, 2026

**Subject:** Planning Department Update

---

### 1. UPDATES

Department of Commerce accepted the proposed updates to the City’s Critical Area regulations. These went to Planning Commission last week for a public hearing and recommendation. Staff will be bringing these to you at the March 18<sup>th</sup> meeting. This is the last code update needed for GMA compliance.

Staff continues to work with SmartGov on permitting software build-out. Meetings are taking place twice weekly, with staff generating and testing 10 permit/application templates a week to try to stay on schedule. The tentative “Go-Live” date is April 21.

---

### 2. DEVELOPMENT ACTIVITY

The projects known as “Pilchuck Crossing” and “Moonbird Farms” are under review. Staff continues to receive inquiries regarding new development.

Tractor Supply has indicated that they intend to submit an application in March.

---

### 3. PERMITS ISSUED

Applicant Name	Address	Type of Work
Elite Roofing	102 S. Granite	Re-roof

The permit listed above is for a re-roof of the Omega Pizza building.

---

#### **4. LONG-RANGE PLANNING**

Staff will be reviewing/proposing changes to the “Change of Use” section of Title 19 in the near future. This relates to buildings such as the old Rite Aid that have been vacated for a period of time, governing what improvements or upgrades may be needed in order to re-occupy the site.

Staff will continue to review and identify areas in need of refinement and revision, bringing forward amendments later this year.

---

#### **5. POLICY AND PROCESS IMPROVEMENTS**

With the implementation of SmartGov, staff anticipates the need to update/complete new SOP’s for all processes as we adjust and adapt to the new system.

---

#### **6. UPCOMING PRIORITIES**

Staff’s top priority is the implementation of SmartGov and processing of Land Use applications. Once SmartGov is live, staff will shift focus to other items identified on the 2026 work plan previously provided. If there are any sections of code that you feel should be prioritized, please share those with me.

---

#### **7. SUMMARY**

Staff focus has shifted to current development project review, while continuing to focus on building out SmartGov and training new staff.



CITY OF  
GRANITE FALLS

## CITY COUNCIL AGENDA BILL

**Subject:** 5.c.

**Originating Dept.:** City Clerk

**Action Recommended:**

**Approval(s):** City Clerk

**Meeting Date:** March 4, 2026

**Date Submitted:**

**Exhibit(s):**

1. 03-04-2026 City Clerk Report

---

**Budgeted Amount:**

**BARS Code:**

---

**Summary Statement:**

---

**Background:**

---

**Recommended Motion:**

**City Clerk Staff Report  
March 4, 2026**

**Business Licenses (Inside City):**

*The Nest (Early Bird Barber LLC)*  
106 S. Granite Ave.  
Granite Falls, WA 98252-8416  
Business license application is for: Cosmetology, esthetician, barber

*Yarbrough and Yarbrough*  
206 Angeline Ave.  
Granite Falls, WA 98252-8785  
Business license application is for: Craft/art sales, delivery service, pet sitting, musician, author

*Red Panda Cards (Red Panda Enterprises LLC)*  
17608 Maple St.  
Granite Falls, WA 98252-9038  
Business license application is for: Online sales of sports cards and other trading card games

**Business Licenses (Outside City):**

*Infinity Lashes and Skincare LLC*  
4008 133<sup>rd</sup> St. SE, Ste. 107  
Mill Creek, WA 98012  
Business license application is for: Salon services and corresponding retail product sales

*The Cleaning Sisters LLC*  
1757 Woodland PL  
Mount Vernon, WA 98274-8959  
Business license application is for: Cleaning service

**Misc. Clerk Information:**

- ✚ I was notified that TC (Tom Collins), former Councilmember, passed away on February 23<sup>rd</sup>
- ✚ Deputy City Clerk Carole Williams and myself will be out March 16<sup>th</sup>-20<sup>th</sup> attending the WMCA Conference in Kennewick



CITY OF  
GRANITE FALLS

**CITY COUNCIL AGENDA BILL**

**Subject:** 5.d.

**Originating Dept.:** Public Works

**Action Recommended:**

**Approval(s):**

**Meeting Date:** March 4, 2026

**Date Submitted:**

**Exhibit(s):**

1. PublicWorksStaffReport 3-4-2026

---

**Budgeted Amount:**

**BARS Code:**

---

**Summary Statement:**

---

**Background:**

---

**Recommended Motion:**

# Public Works Staff Report

## March 4, 2026

### STREETS

Public Works completed crack sealing on Leola Lane. This area had large cracks, some exceeding 1 inch in width.

Staff has sent out the 2026 Crack Seal Project scope of work. Nearly 400 companies were solicited for the project. The project outlines crack sealing of roughly 55,400 linear feet of cracks along thirteen segments. The bid deadline is March 10, 2026.

**2026 Crack Sealing Map**



Public Works received the torchdown material needed to replace the worn stop bars and crosswalk pads at the Stanley/Granite intersection. A traffic control plan has been created, and once the weather allows, staff will coordinate with Community Transit and the Fire District to notify them of traffic interruptions prior to work beginning.

### STORM

Staff submitted the 2025 Stormwater Annual Report to the Washington State Department of Ecology. As previously mentioned, the report summarizes annual efforts toward meeting elements of the National Pollutant Discharge Elimination System (NPDES) permit.

## **SEWER**

Public Works recently replaced the flush valve on Pump 2 at the Suncrest Lift Station. The previous flush valve was originally installed in 2017 and, over the last year, began to fail, causing excessive run times on the pump. The old flush valve was rebuilt multiple times over the years and has been placed in stock as a spare.

## **MISC.**

A message was added to the most recent utility bills to help guide residents interested in signing up for the mass text messaging service. There are two primary ways to sign up: geo-based alerts through the My Alerts app and text-in options for joining groups.



### **Alerts & Notifications**

Please sign up for alerts and notifications from the City of Granite Falls.

- Text **"GFALL"** to receive notifications for all topics below
- Text **"Granitefallswa"** for emergency alerts
- Text **"GFGEN"** for general notifications
- Text **"GFPR"** for parks and recreation notifications
- Text **"GFTT"** for traffic and transportation notifications
- Text **"GFWASE"** for utility-related notifications

To **38276**

These alerts are provided free of charge; however, standard text messaging rates and other charges may apply. There is also a mobile app, **"My Alerts"** available for weather notifications and location-based notifications. Get it on [Google Play](#). Download on the [App Store](#).



CITY OF  
GRANITE FALLS

## CITY COUNCIL AGENDA BILL

**Subject:** 5.e.

**Originating Dept.:** City Clerk

**Action Recommended:**

**Approval(s):**

**Meeting Date:** March 4, 2026

**Date Submitted:**

**Exhibit(s):**

1. March 4th 2026 Police report for February

---

**Budgeted Amount:**

**BARS Code:**

---

**Summary Statement:**

---

**Background:**

---

**Recommended Motion:**



## City of Granite Falls In Partnership with Snohomish County Sheriff's Office



**Sheriff Susanna Johnson**

**City Manager Jeff Balentine**

Mayor and Councilmembers,

**Granite Falls Council Report – February 2026**

**As of February 26, 2026**

Overall incidents continue to trend downward in 2026. Month-to-date, Deputies have responded to 681 calls for service (CFS), compared to 769 in 2025 and 838 in 2024 for the same period. While total CFS are down, proactive enforcement activity is up. Officer-initiated activity accounts for 46% of calls this year, compared to 43.5% in 2025 and 39% in 2024—reflecting a continued emphasis on visible, proactive policing. Alarm calls (15 vs. 18), animal control calls (7 vs. 9), suspicious activity (68 vs. 77), trespass complaints (6 vs. 14), and public assistance calls (19 vs. 31) all decreased.

The reduction in public assistance calls is largely attributed to minimal winter weather impacts along the Mountain Loop Highway, resulting in fewer stranded motorists and outdoor recreation-related responses. Deputies completed 30 case reports, consistent with 2025 and down from 43 in 2024. Notably, there were no reported burglaries or simple assaults this month. Deputies responded to nine domestic-related incidents, resulting in five Assault 4–DV arrests. Behavioral health contacts increased significantly (23 in 2026 compared to 8 in 2025), with nine suicidal subject responses. Welfare checks declined to 12 (29 in 2025). Deputies also investigated one death, handled seven abandoned vehicles, took one stolen vehicle report, and recovered four stolen vehicles.

Traffic enforcement and visibility efforts remained strong. Deputies conducted 71 traffic stops, issued 23 citations associated with 27 infractions, and responded to 12 collisions (eight within city limits). School safety remains a priority, with 24 school checks and 14 security checks conducted this month. Deputies responded to six 911 calls involving schools, two CPS cases, two civil matters, one trespass, and one significant suspicious incident. On February 24, a first grader reported an armed subject hiding in bushes near the school. Deputy response was immediate, with the first Deputy on scene within 30 seconds of the RAVE alert and five Deputies present within 90 seconds. A thorough investigation determined the report to be unfounded, highlighting both the importance of rapid response and coordinated communication.

In addition to operational activity, we hosted the Chiefs and Sheriff's meeting at the new fire station with approximately 55 attendees. I want to thank the Fire Department for the use of their facility and IGA for providing breakfast. Due to space and acoustics,



**City of Granite Falls  
In Partnership with  
Snohomish County Sheriff's Office**



**Sheriff Susanna Johnson**

**City Manager Jeff Balentine**

future Coffee with the Chief meetings will also be moved to the fire station. We appreciate Alf's for hosting these gatherings and their continued community partnership.

Respectfully submitted,

*Tom Dalton #1508*

Chief Tom Dalton



## CITY COUNCIL AGENDA BILL

**Subject:** 7.a.

**Originating Dept.:** City Manager

**Action Recommended:**

**Approval(s):** City Manager

**Meeting Date:** March 4, 2026

**Date Submitted:**

**Exhibit(s):**

1. Granite Falls - Slide Deck-2
- 

**Budgeted Amount:**

**BARS Code:**

---

**Summary Statement:**

Capital Path Consulting, the City's Lobbyist, will be providing a Legislative update to City Council on State and Federal progress as it relates to the City of Granite Falls. See Attached Flyer for details.

---

**Background:**

---

**Recommended Motion:**

---



# CAPITOL PATH

— CONSULTING —

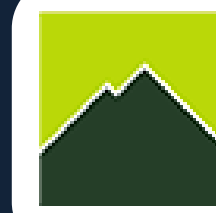

## State and Federal Advocacy Goals for 2026

- Protect rural infrastructure
- Advance priority capital projects
- Position the City for state and federal funding
- Increase visibility with legislative offices



# State Legislative Update



# State Legislative Updates

As of February 26, 2026

## General Update

Washington State Operating Budget Overview (2025–27 Biennium)

- Proposed biennial spending: \$79.2–\$79.3 billion
- About \$1.5 billion above last biennium

Cost pressures driven by:

- Increased demand in childcare, health care, higher education, and core services
- Reduced federal support
- Rising legal settlements, largely tied to the child welfare system

## Spending Reductions & Savings

**Both chambers' budget proposals target ~\$2.4 billion in four-year savings**

Senate approach:

- ~\$800 million reduction in low-income childcare programs
- Prioritizes Medicaid, long-term care, disability services, food assistance

House approach:

- 3% administrative cut across state agencies
- Additional 1.5% reduction for higher education
- Slows childcare expansion, less than Senate proposals



# State Legislative Updates

As of February 26, 2026

## Reserves & Fund Shifts

Rainy Day Fund use:

- \$750 million (Senate)
- \$880 million (House)

Climate fund repurposing:

- House shifts \$330 million for Working Families Tax Credit
- Senate directs funds to wildfire prevention & response, leaves climate grants intact

## Revenue Debate: Millionaires Tax

- Proposed 9.9% tax on income over \$1 million
- Projected to raise several billion dollars annually starting in 2029
- Expected court challenges and possible referendum

Ongoing debate over use of funds:

- Some lawmakers favor reducing previously raised taxes
- Others want to fund K-12 education and core state programs



# State Legislative Updates

As of February 26, 2026

Potential Success	
Project	Funding Amount
Legion Park Plaza Veteran's Memorial	\$93,000
Community Campus Parking Lot	\$463,000

**Next Steps:**

- House budget passes out of committee
- House budget voted on the floor
- Potential amendments to budget
- Conference

# Federal Update

# FY26 Appropriations Funding Award

<b>Senator Patty Murray Awarded</b>
<b>\$990,000</b>

## Project: City of Granite Falls Burn Rd Wastewater Lift Station Rehabilitation

**Project Summary:** The City of Granite Falls is requesting \$990,000 in federal CDS funding to rehabilitate the aging Burn Road Wastewater Lift Station to prevent system failure and wastewater overflows into the Snohomish and Pilchuck Rivers. The project protects water quality and critical salmon habitat, while addressing an immediate public health risk, as a failure could back wastewater into the local elementary school.



**CITY OF  
GRANITE FALLS**

**Wastewater Station  
at Risk of Failure**



---

**PROJECT SUMMARY**

The City of Granite Falls' current wastewater lift station is out of date and needs significant repairs to avoid a catastrophic failure.

The City is seeking **\$1.32M** in infrastructure funding to complete the necessary rehabilitation of the Burns Rd. wastewater lift station.

The project will replace aging equipment with energy efficient pumps and back up generators, bringing the station to modern standards.

Due to proximity of the Burns Rd. lift station to a local elementary school and Snohomish River, if the substation fails both the school and river could be flooded with waste water, creating a public health and environmental crisis.



● Elementary School ★ Burns Rd. Station

Failure of the station would cause the local elementary school to close

Failure of the current wastewater treatment station could create and **public health and environmental crisis**

Current Wastewater Treatment Plant project does not fund the necessary repairs to the Burns Rd. Facility



Scan to find out more about the Granite Falls Waste Water Treatment Project



# Federal Project Update

As of February 26, 2026

## Water and Sewer Upgrade Project

- Appropriations Request for \$750,000
- Request is in its final drafting stage and being prepared for submission.
  - Representative Kim Schrier
  - Senator Maria Cantwell
  - Senator Patty Murray

### Protecting Water Protecting Community

**PROJECT PURPOSE**  
Granite Falls seeks federal support to design and engineer municipal sewer and water extensions that will **eliminate decentralized septic discharge within the watershed of the Stillaguamish River**, a critical **salmon-bearing river** supporting spawning habitat and regional recovery efforts.

By replacing on-site septic systems serving existing industrial properties with connection to the municipal wastewater system, this project **reduces long-term nutrient loading to groundwater** that is hydrologically connected to the river. Protecting groundwater quality helps **safeguard surface water** conditions essential to salmon recovery.



Federal Request  
**\$750K**

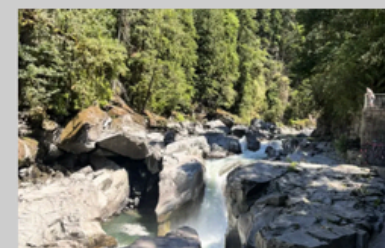

Approx. Pop.  
**4,750**

### WHY THIS INVESTMENT IS IMPORTANT

- Supports **salmon recovery** through **watershed-based pollution prevention**
- **Protects a designated municipal groundwater source** before costly remediation is required
- Advances **proactive water quality protection** in Snohomish County
- Strengthens **rural infrastructure resilience**

# Advocacy Timeline & Next Steps

## CPC Led Federal Appropriations Timeline

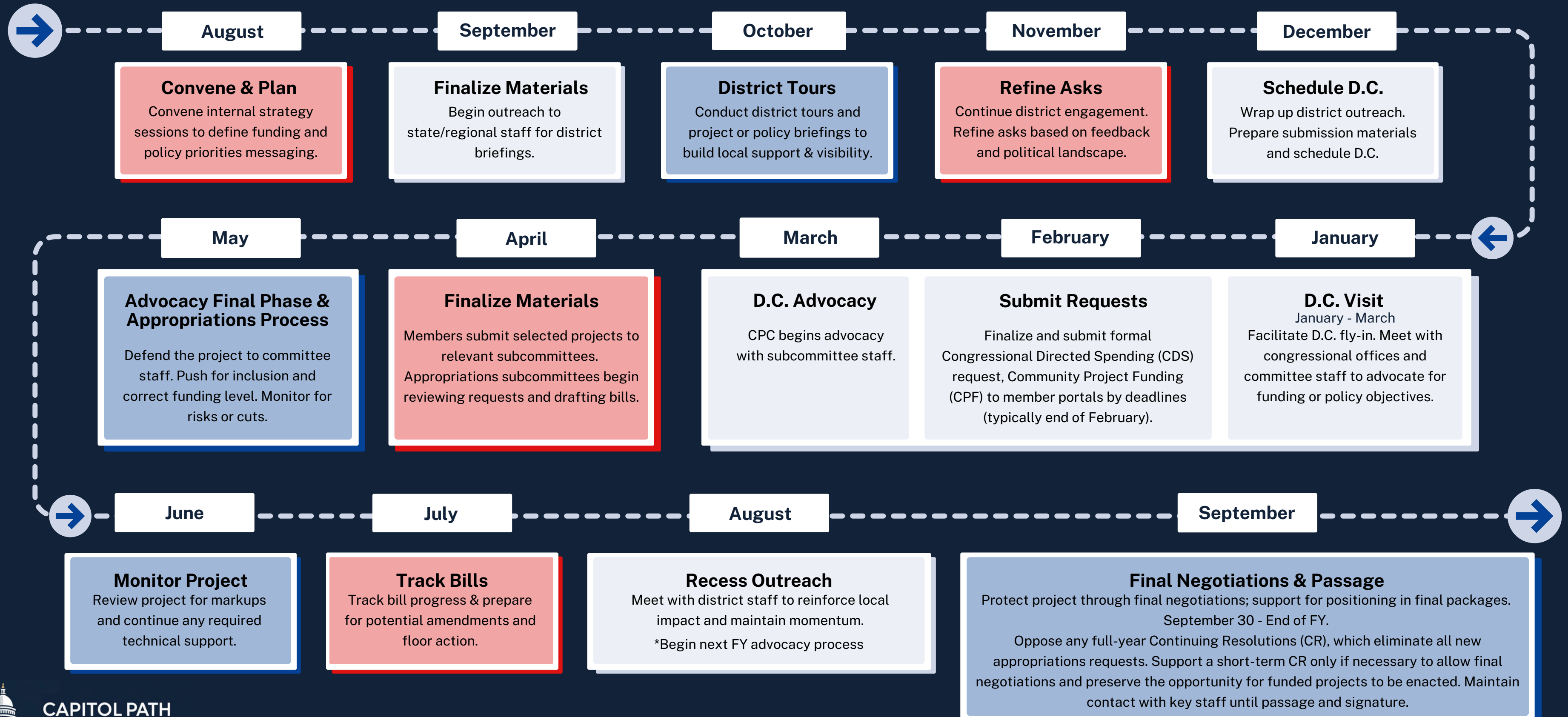

# 2026 Potential Grant Projects



Legion Park  
Outdoor Plaza



Water & Wastewater  
Infrastructure



Regional Sports  
Complex

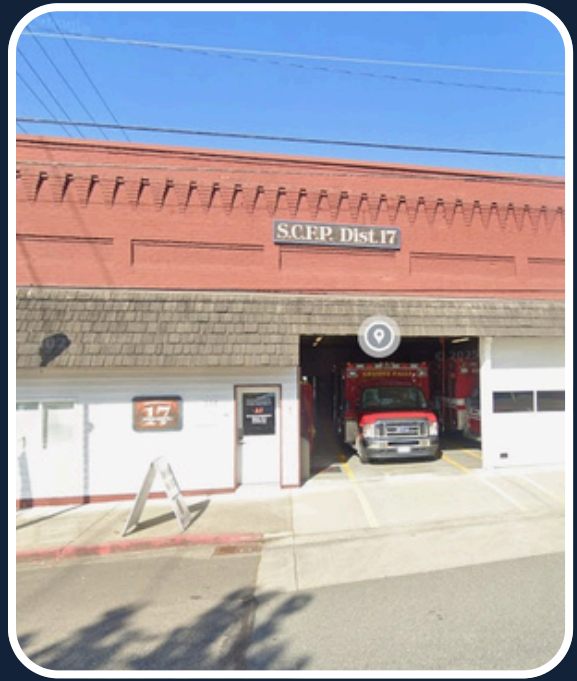

Community Center  
Redevelopment



Playground Equipment  
Replacement



School Resource  
Officer Program



Park & Ride  
Facility Relocation



EV Charging



# Legion Park Plaza Veteran's Memorial

Project Focus: Development of an outdoor plaza space within Legion Park to create a flexible, year-round community gathering area.

This project will:

- Expand usable public space for events, markets, and community celebrations
- Enhance downtown vitality and small business activity
- Improve accessibility, safety, and site amenities
- Strengthen recreation appeal

Current and future funding being pursued:

- Washington State Recreation and Conservation Office grants
- State capital budget community and recreation funding
- Federal Land and Water Conservation Fund programs
- Potential local and private partnership contributions

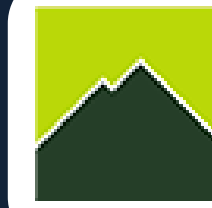

# Water & Wastewater Infrastructure

Projects: Water & Sewer Upgrade, Water Well Infrastructure Feasibility Study, Stormwater Infrastructure Improvements  
Project Focus: System upgrades, compliance, long-term capacity

These projects will:

- Protect public health
- Support the Snohomish watershed
- Prevent costly emergency failures
- Maintain regulatory compliance
- Provide long-term capacity

Current and future funding being pursued:

- EPA State Revolving Funds
- WRDA Section 219
- Congressional Community Project Funding
- USDA Rural Development



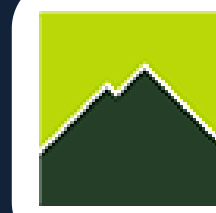

# Regional Sports Complex

Project Focus: Development of a regional sports and recreation complex to serve Granite Falls and surrounding rural communities.

This project will:

- Expand youth recreation opportunities
- Reduce travel burden for local families
- Support tournaments and regional visitation
- Drives small business and tourism activity
- Enhance quality of life and community health

Current and future funding being pursued:

- Washington State Recreation and Conservation Office grants
- State capital budget recreation funding
- Federal Land and Water Conservation Fund programs
- Potential public-private partnerships



# Community Center Redevelopment

Project: Conversion of former Fire Station at 116 S. Granite Avenue

This project will:

- Provide a dedicated space for youth, seniors, and community programming
- Allow emergency coordination capability
- Activate an existing public asset
- Support community cohesion and quality of life

Current and future funding being pursued:

- State capital budget community facility funding
- USDA Community Facilities
- Congressional Community Project Funding



# Playground Equipment Replacement

Project Focus: Replacement of aging playground equipment and park amenities to improve safety, accessibility, and overall usability for families.

This project will:

- Ensure compliance with current safety standards
- Improve ADA accessibility
- Reduce liability and long-term maintenance costs
- Support youth health, recreation, and quality of life
- Enhance neighborhood gathering spaces

Current and future funding being pursued:

- Washington State Recreation and Conservation Office grants
- Land and Water Conservation Fund programs
- State capital budget recreation funding
- Community partnerships and local match opportunities



# School Resource Officer Program

Project Focus: Sustain and expand dedicated School Resource Officer presence in local schools.

This project will:

- Enhance student and staff safety
- Builds positive relationships between youth and law enforcement
- Provides early intervention and prevention support
- Reduces strain on patrol resources

Current and future funding being pursued:

- U.S. Department of Justice COPS School Violence Prevention Program
- State public safety grants
- Potential state operating budget support
- Partnership cost-sharing with school district



# Park & Ride Facility Relocation

Project Focus: Relocate and modernize the existing Park & Ride facility to improve safety, traffic flow, and regional transit connectivity.

This project will:

- Support commuter access to regional employment centers
- Reduce congestion in the downtown core
- Improve pedestrian and vehicle safety
- Position the City for future transit partnerships

Current and future funding being pursued:

- Washington State Department of Transportation mobility grants
- Federal surface transportation funding
- Potential regional transit partnerships
- State capital budget transportation appropriations



# Electric Vehicle Charging Infrastructure

Project Focus: Expand electric vehicle charging infrastructure to support residents, visitors, and future sustainable transportation demand.

This project will:

- Encourage clean transportation and reduces greenhouse gas emissions
- Support tourism and regional connectivity
- Position Granite Falls for future economic and transportation growth
- Address rural charging gaps

Current and future funding being pursued:

- Washington Department of Commerce — WA EV Charging Program (WAEVCP)
- WSDOT EV Charging Grants - NEVI
- WSDOT EV Charging Grants - ZEVIP
- Washington Department of Ecology EV Charging Grants

# Monthly Grants Matrix



## Grant Bulletin: February 2026 to April 2026

The purpose of this communication is to list available grant opportunities over the coming two months to alert clients as to opportunities available and details of each within the February 2026 to April 2026 timeframe.

	Name	Deadline	Description	Website	Prerequisite	Contact Email	Funding Bucket	Max Funding	Local Match	Publish Date	Potential Qualifying Projects
<b>Community Development</b>											
1	Washington State Dept of Commerce Community Economic Revitalization Board (CERB)	3/30/2026	Studies to evaluate high-priority economic development and rural broadband projects.	<a href="https://www.commerce.wa.gov/cerb/cerb-p/">https://www.commerce.wa.gov/cerb/cerb-p/</a>	Economic Development Related - Industrial, Office. Also, letter of support from Associated Development	<a href="mailto:janea_stark@commerce.wa.gov">janea_stark@commerce.wa.gov</a>	\$40,000,000	\$100,000	20%	2/1/2026	
2	Walmart Sparks Grants	4/15/2026, 7/15/2026, 10/15/2026, and 12/31/2026	Grants need to be within economic opportunity, sustainability, or strengthening community.	<a href="https://www.walmart.org/how-we-give/program-guidelines/spark-good-local-grants-guidelines">https://www.walmart.org/how-we-give/program-guidelines/spark-good-local-grants-guidelines</a>	Get nomination from nearest Walmart Store or Warehouse.	Walmart Staff	Unknown	\$5,000	None	2/1/2026	
3	T-Mobile Hometown Grant	3/31/2026	We'll help fund projects that foster local connections, like technology upgrades, outdoor spaces, the arts and	<a href="https://www.t-mobile.com/brand/hometown-grants">https://www.t-mobile.com/brand/hometown-grants</a>	Maintenance Plan on asset moving forward. Less than 50,000. Programs to help community spaces.	<a href="mailto:info@mainstreet.org">info@mainstreet.org</a>	\$5,000,000	\$50,000	50%	2/1/2026	
4	Washington Dept of Commerce Clean Buildings Performance Standard Grants	3/4/2026	This grant offers competitive funding for energy audits and improvements on public and privately owned buildings that	<a href="https://www.commerce.wa.gov/cbps/cbps-grants-incentives/cbps-performance-grants/">https://www.commerce.wa.gov/cbps/cbps-grants-incentives/cbps-performance-grants/</a>	Getting public and private buildings in conformance with State Clean Building Performance Standard PCW	<a href="mailto:cbpsgrants@commerce.wa.gov">cbpsgrants@commerce.wa.gov</a>	\$10,000,000	\$2,000,000	25%	1/30/2026	
5	Washington Department of Commerce Housing Trust Fund Repair Fund	Rolling	This grant will pay for urgent, non-recurrent repairs in eligible affordable housing properties.	<a href="https://deptofcommerce.app.box.com/s/o7n4d4vbor7g3onwbqb8kzgdheoyd7hg">https://deptofcommerce.app.box.com/s/o7n4d4vbor7g3onwbqb8kzgdheoyd7hg</a>	Urgent, non-recurrent repairs in eligible affordable housing properties.	<a href="mailto:hftrepair@commerce.wa.gov">hftrepair@commerce.wa.gov</a>	\$6,000,000	\$200,000	50%	1/28/2026	
6	National Endowment for the Arts Project 1	2/12/2026	Our-Town Stuff, Arts Education, Dance, Local Arts Agencies, Musical Theater, and Visual Arts.	<a href="https://simpler.grants.gov/opportunity/d66a8e60-580c-4d7b-b72f-04de6967c95b">https://simpler.grants.gov/opportunity/d66a8e60-580c-4d7b-b72f-04de6967c95b</a>	Either a 501c3 non-profit or a local government	<a href="mailto:apply@arts.gov">apply@arts.gov</a>	\$65,000,000	\$100,000	50%	12/11/2025	
<b>I. Facilities</b>											
<b>II. Fire Department</b>											
<b>V. General Government</b>											
1	Office of State Treasurer LOCAL Program	Rolling	The LOCAL program provides Washington municipalities with a cost-effective way to	<a href="https://tre.wa.gov/financing-and-debt/get-financing/local-government-financing">https://tre.wa.gov/financing-and-debt/get-financing/local-government-financing</a>	Municipality is credit worthy.	<a href="mailto:localprogram@tre.wa.gov">localprogram@tre.wa.gov</a>	Varies	Varies	Varies	Rolling	

# Thank You



**John Culton**  
Principal



**Kyla Shkerich Blair**  
Principal



**Daniel Pailthorp**  
Senior Associate



**Amelia Alberts**  
Senior Grant Writer



**Sharon Carvo**  
Creative Director



**Marci Miller**  
Business Manager &  
Senior Advisor





## CITY COUNCIL AGENDA BILL

**Subject:** 7.b.

**Originating Dept.:** Planning  
Department

**Action Recommended:**

**Approval(s):**

**Meeting Date:** March 4, 2026

**Date Submitted:**

**Exhibit(s):**

1. UW\_Granite\_Falls\_ICR\_Presentation\_Mar4\_2026

---

**Budgeted Amount:**

**BARS Code:**

---

**Summary Statement:**

The City has again partnered with the LCY Program and UW students on development of the City's Hazard Mitigation Plan Annex. Students have completed their Initial Conditions Report and will be presenting to Council.

---

**Background:**

During the 2025–2026 academic year, the Livable City Year (LCY) Program at UW is partnering with the City of Granite Falls to support the development of the City's Hazard Mitigation Plan. As required under federal and state emergency management guidelines, the City is drafting a local annex to Snohomish County's Hazard Mitigation Plan. This annex will formally document the City's specific risks, vulnerabilities, and mitigation strategies while ensuring eligibility for certain state and federal hazard mitigation funding programs.

Through this partnership, LCY participants are contributing research, risk assessment, and community engagement support to help identify local hazards, assess community vulnerabilities, and develop actionable mitigation strategies. The annex will serve as a guiding document to strengthen the City's preparedness, response, recovery, and long-

term resilience.

The students are presenting their progress so far in this mid-quarter presentation which includes the Initial Conditions Report (ICR).

---

**Recommended Motion:**

# GRANITE FALLS HAZARD MITIGATION: ICR Presentation

*City Council Presentation*

March 4<sup>th</sup> 2026



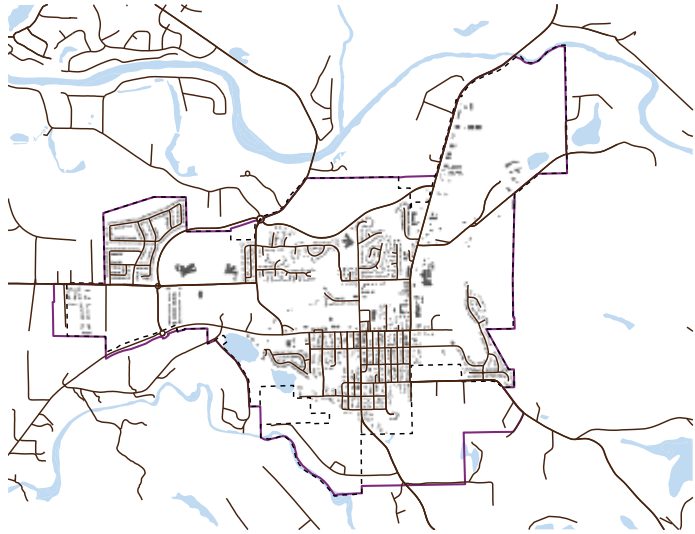

# OVERVIEW

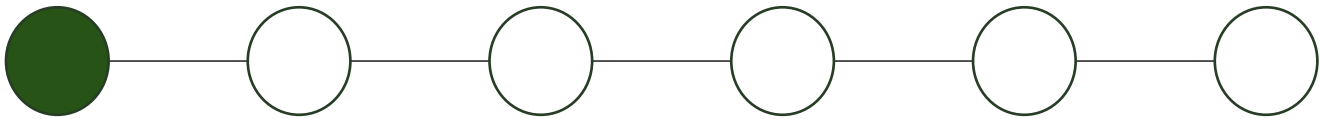

# AGENDA



1 Project Overview and Description

2 Land Use, Transportation and Natural Resources

3 Infrastructure and Public Works

4 Housing and Economic Development

5 Public, Health, and Cultural Facilities

6 Project Roadmap and Q+A

# AGENDA

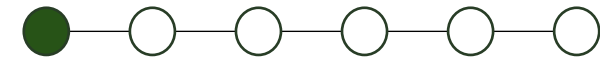

1 Project Overview and Description

2 Land Use, Transportation and Natural Resources

3 Infrastructure and Public Works

4 Housing and Economic Development

5 Public, Health, and Cultural Facilities

6 Project Roadmap and Q+A

Key Findings

Insights

# OVERVIEW

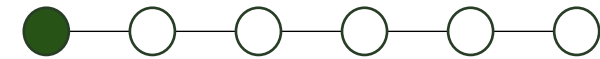

The **City of Granite Falls** and **Livable City Year** are working together to produce a Hazard Mitigation Plan.



The team has put together a report on key information related to hazards. This Initial Conditions Report (ICR) **provides the groundwork** to create the Hazard Mitigation Plan this Spring.



This presentation will **provide the key findings** of the ICR.

# WHAT IS A HAZARD MITIGATION PLAN?

- **Identifies and reduces risk:** An HMP outlines local hazards and prioritizes actions to reduce or prevent damage from disasters.
- **Keeps communities eligible for federal funding:** A current, FEMA-approved HMP is required for jurisdictions to receive disaster-related federal grants.
- **Ensures ongoing preparedness:** The plan must be regularly updated so communities can reassess risks, track progress, and strengthen long-term mitigation strategies.

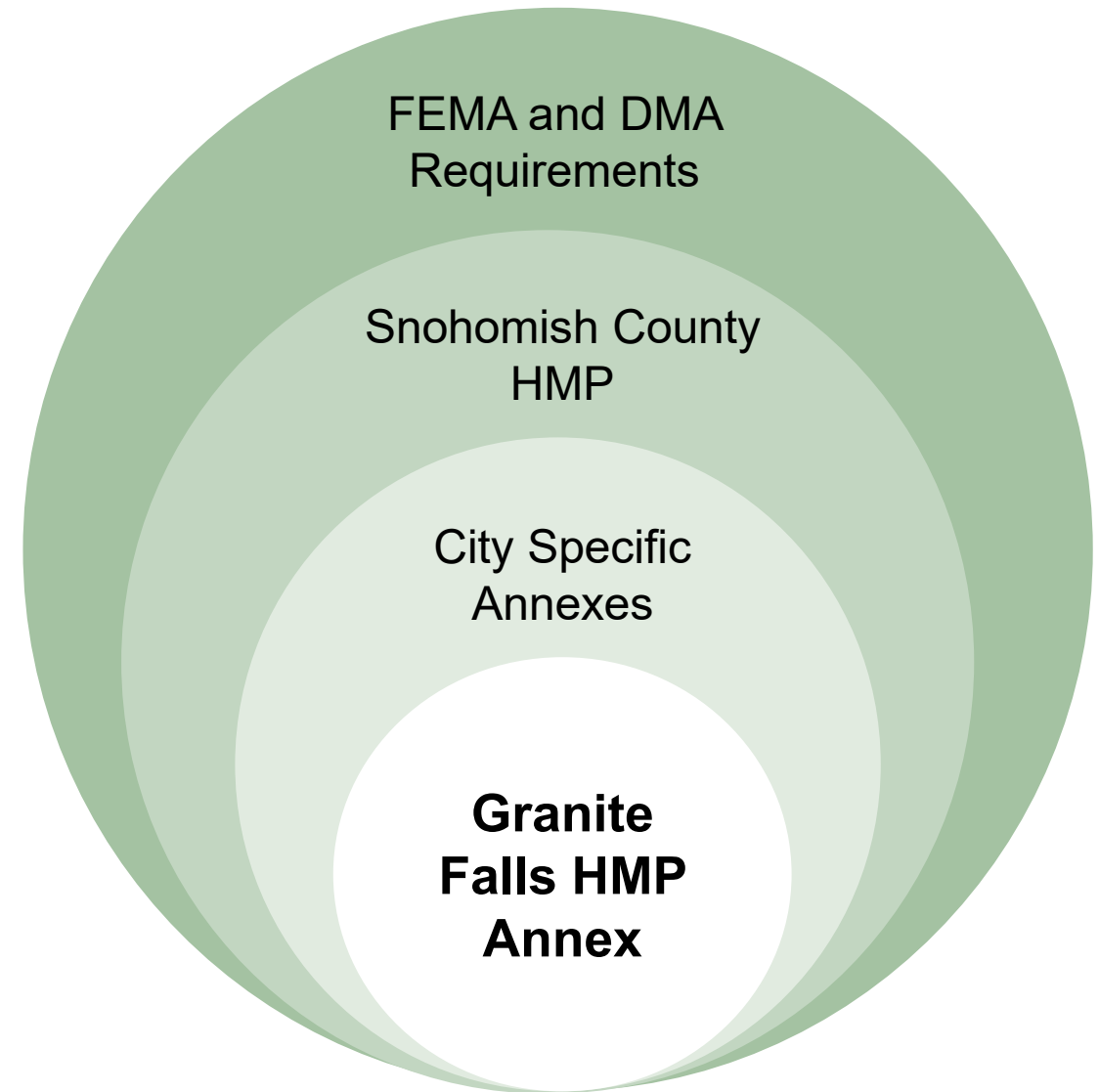

# WHAT HAZARDS ARE BEING ANALYZED



Earthquake



Wildfire



Volcano



Mass Earth  
Movement

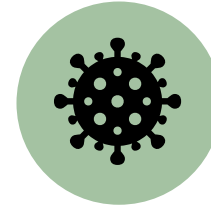

Disease Outbreak



Flood



Cybersecurity



Severe Weather  
Events



Aircraft Accident



Extreme Heat and  
Drought



Active Assailant



Dam Failure

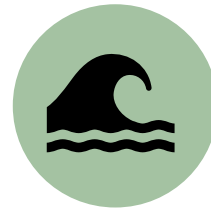

Tsunami

# WHAT INFORMATION IS INCLUDED

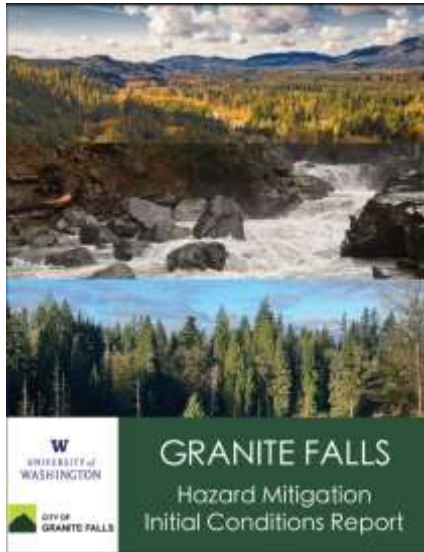

*Early June*

## This ICR includes:

- Brief community profile and history of hazards in Granite Falls
- Inventory of city resources and infrastructure
- Analysis of hazard impacts
- Complete mapping of hazards

## The Hazard Mitigation Plan will include:

- Jurisdiction-specific risk summary
- Hazard probability, exposure and vulnerability
- Critical infrastructure risk
- Hazard mitigation strategies



# LAND USE, TRANSPORTATION, AND NATURAL RESOURCES

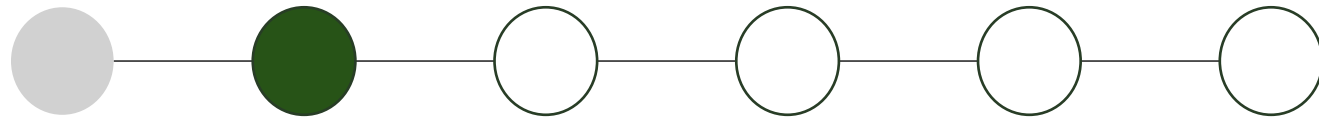

# KEY FINDINGS

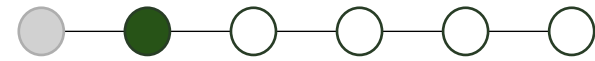

1

**Low Density Residential and Riverfront Residential Zones** are the most at-risk for **wildfire and flooding**.

2

**Bus routes** are concentrated around Downtown Residential, Central Business District, Multiple Housing and Public/Institutional Zones.

3

The majority of Granite Falls is considered a **wildland urban interface (WUI)**, increasing likelihood of a catastrophic wildfire and requiring specific interventions.

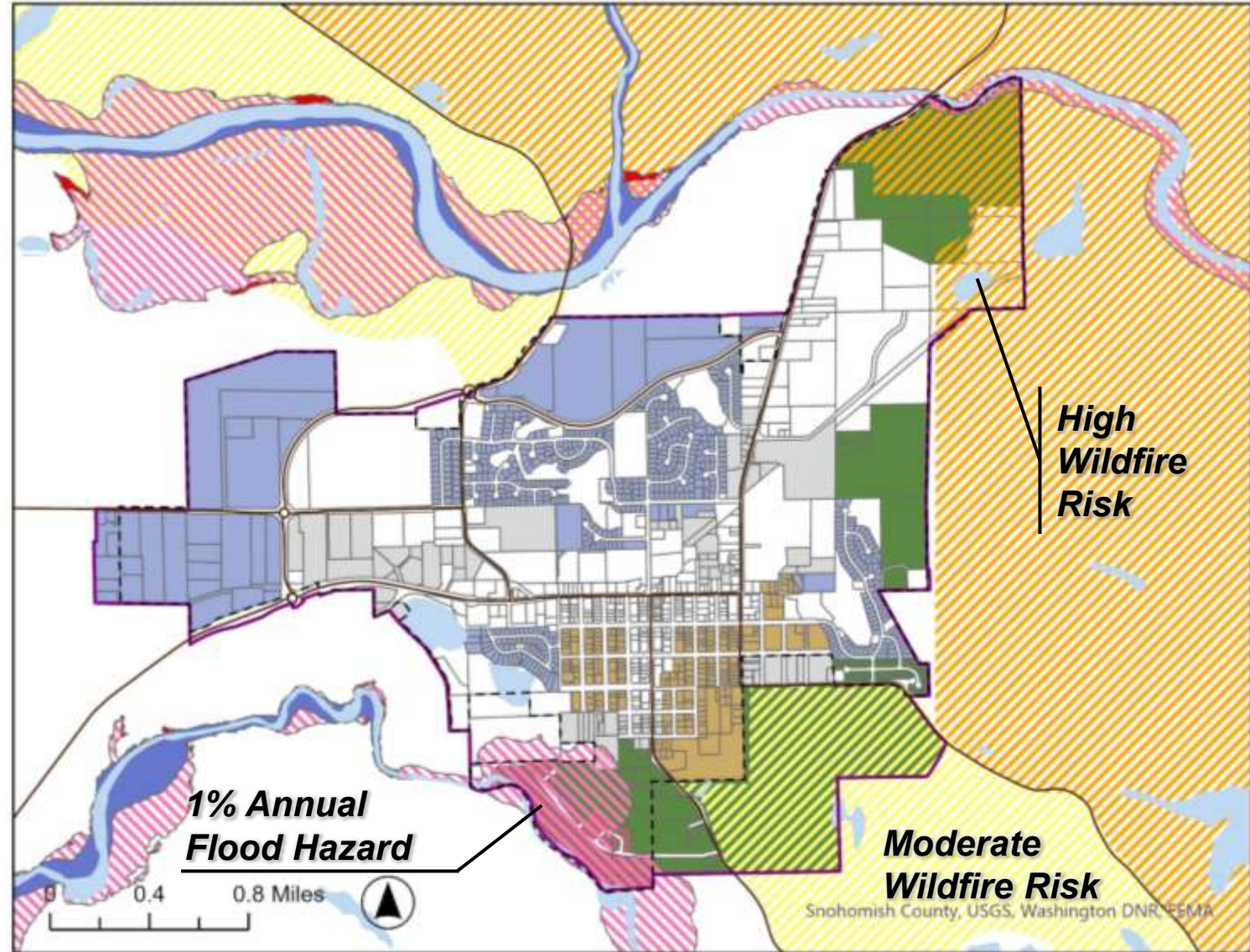

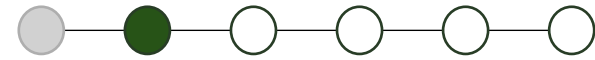

# KEY FINDINGS

1

Low Density Residential and Riverfront Residential Zones are the most at-risk for wildfire and flooding.

2

Bus routes are concentrated around Downtown Residential, Central Business District, Multiple Housing and Public/Institutional Zones.

3

The majority of Granite Falls is considered a **wildland urban interface (WUI)**, increasing likelihood of a catastrophic wildfire and requiring specific interventions.

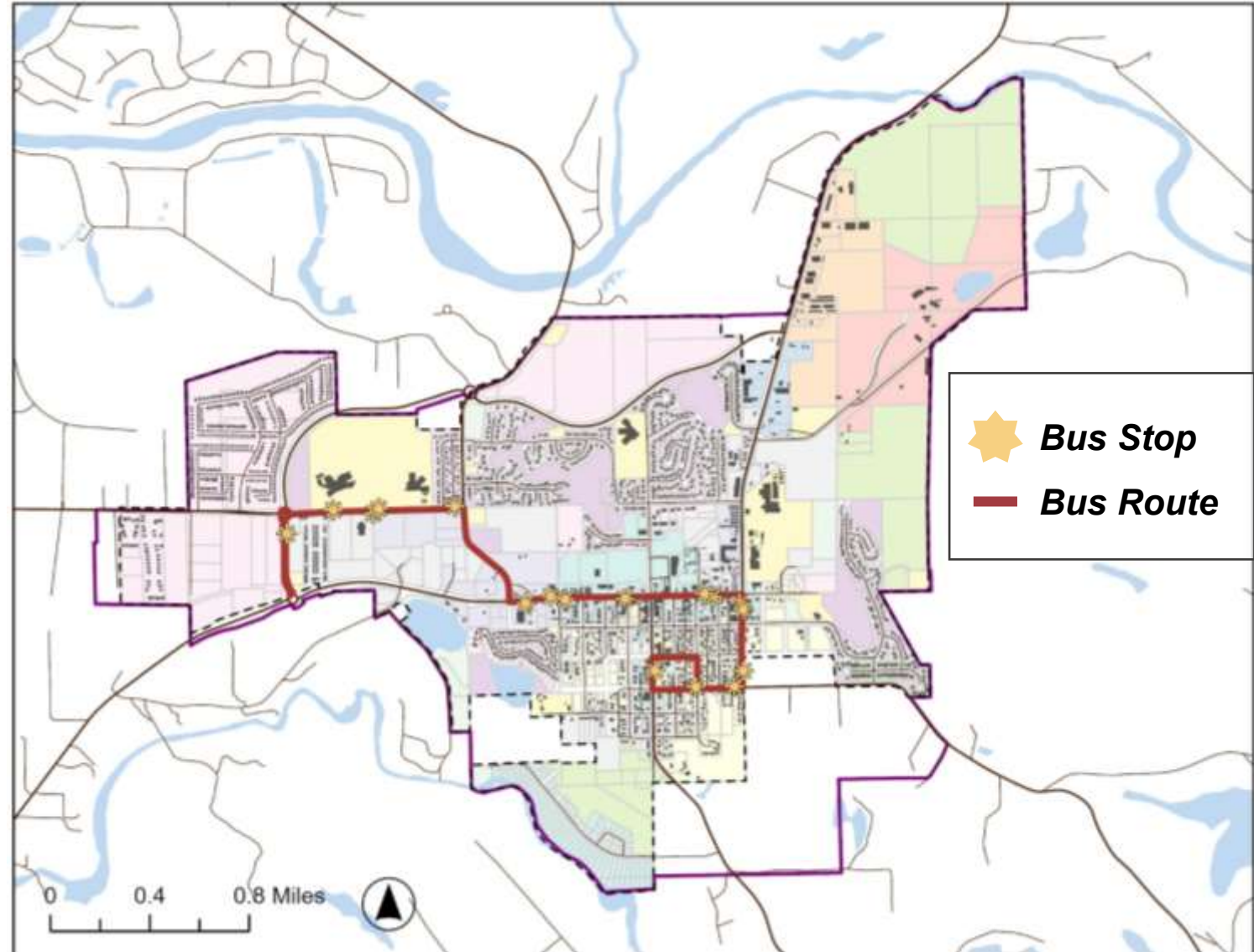

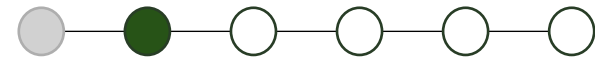

# KEY FINDINGS

1

Low Density Residential and Riverfront Residential Zones are the most at-risk for wildfire and flooding.

2

Bus routes are concentrated around Downtown Residential, Central Business District, Multiple Housing and Public/Institutional Zones.

3

The majority of Granite Falls is considered a **wildland urban interface (WUI)**, increasing likelihood of a catastrophic wildfire and requiring specific interventions.

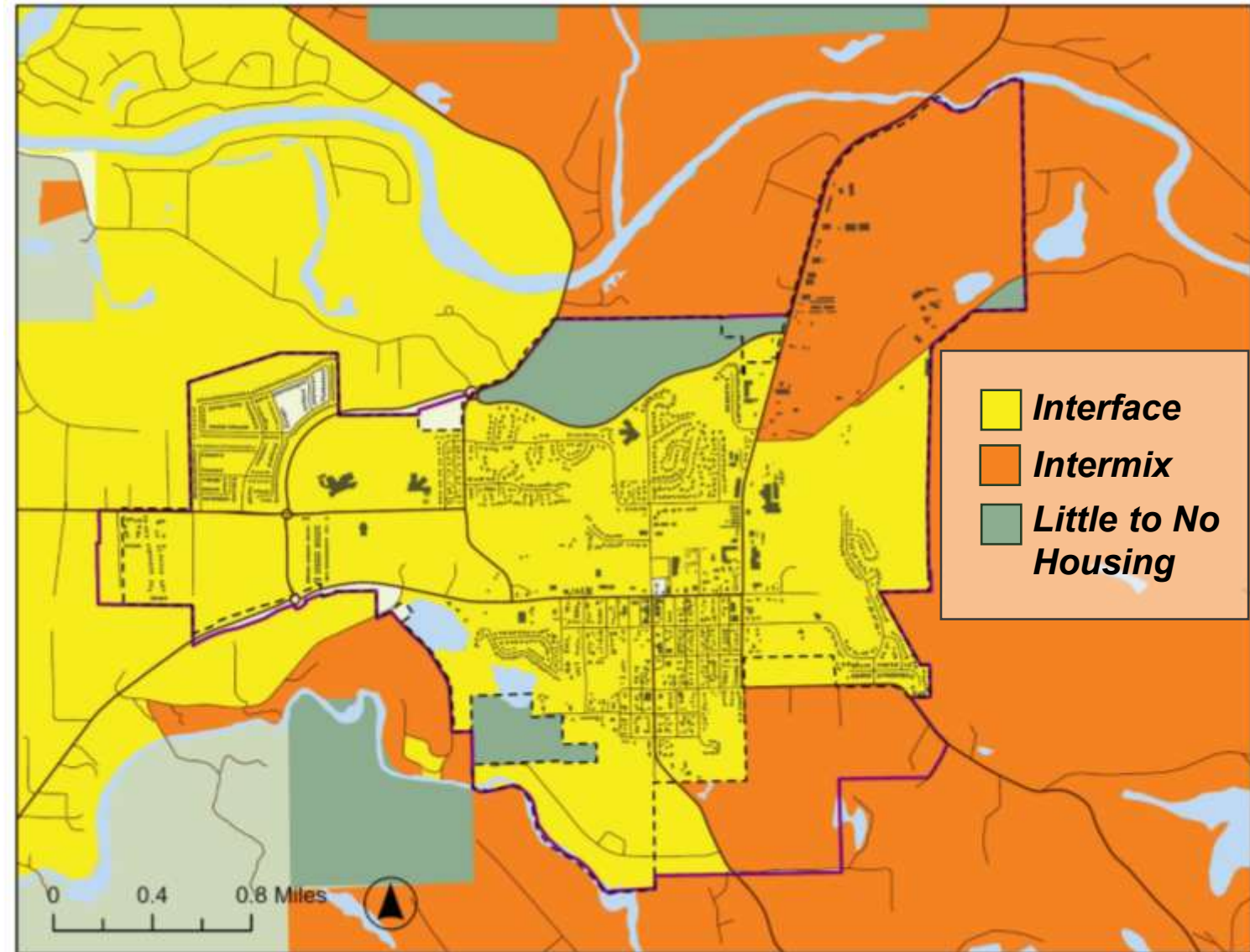

# INSIGHTS

1

**Wildfire and landslide hazards** pose a threat to current and future **residential land-use**; mitigation efforts will require significant community engagement.

2

Limited access and resource availability due to geographic isolation makes **freight transit essential**.

3

There are roughly **105 acres of wetlands** within the city and UGA boundaries, which **support flood mitigation and critical wildlife habitat**.

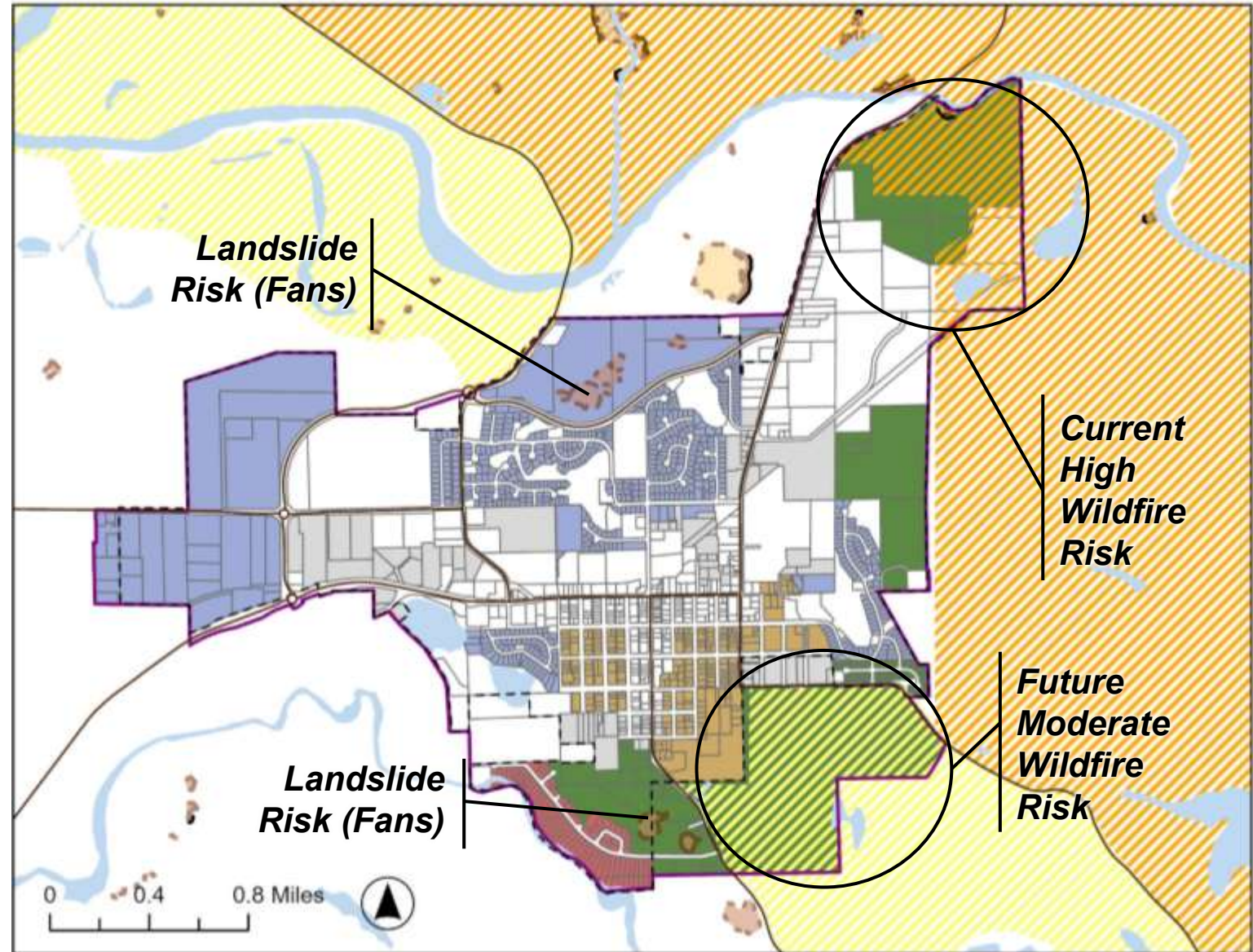

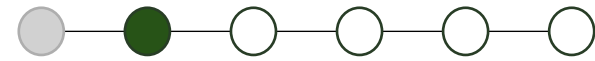

# INSIGHTS

1

Wildfire and landslide hazards pose a threat to current and future **residential land-use**; mitigation efforts will require significant community engagement.

2

Limited access and resource availability due to geographic isolation makes **freight transit essential**.

3

There are roughly **105 acres of wetlands** within the city and UGA boundaries, which **support flood mitigation and critical wildlife habitat**.

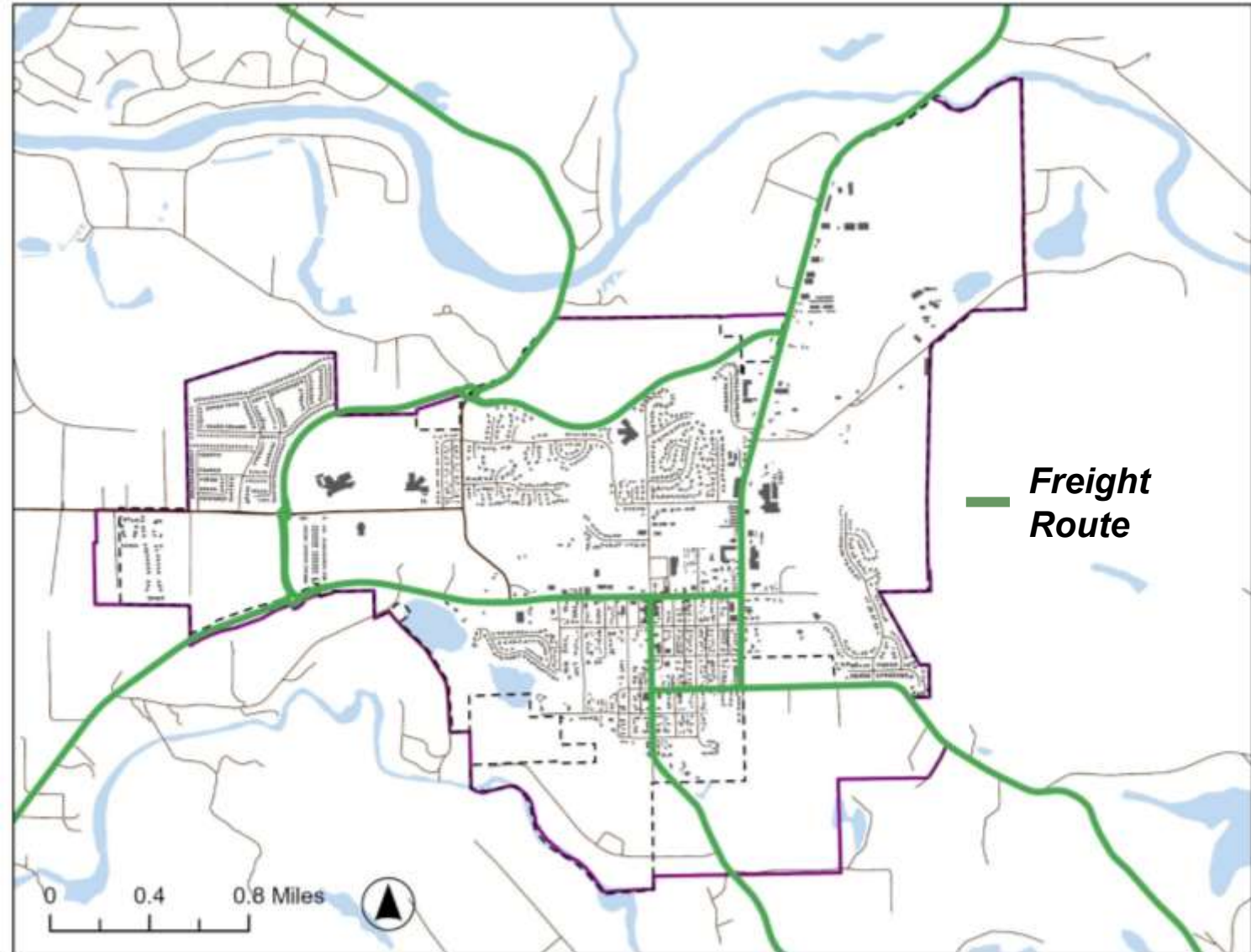

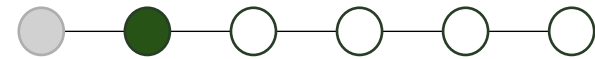

# INSIGHTS

1

Wildfire and landslide hazards pose a threat to current and future **residential land-use**; mitigation efforts will require significant community engagement.

2

Limited access and resource availability due to geographic isolation makes **freight transit essential**.

3

There are roughly **105 acres of wetlands** within the city and UGA boundaries, which **support flood mitigation and critical wildlife habitat**.

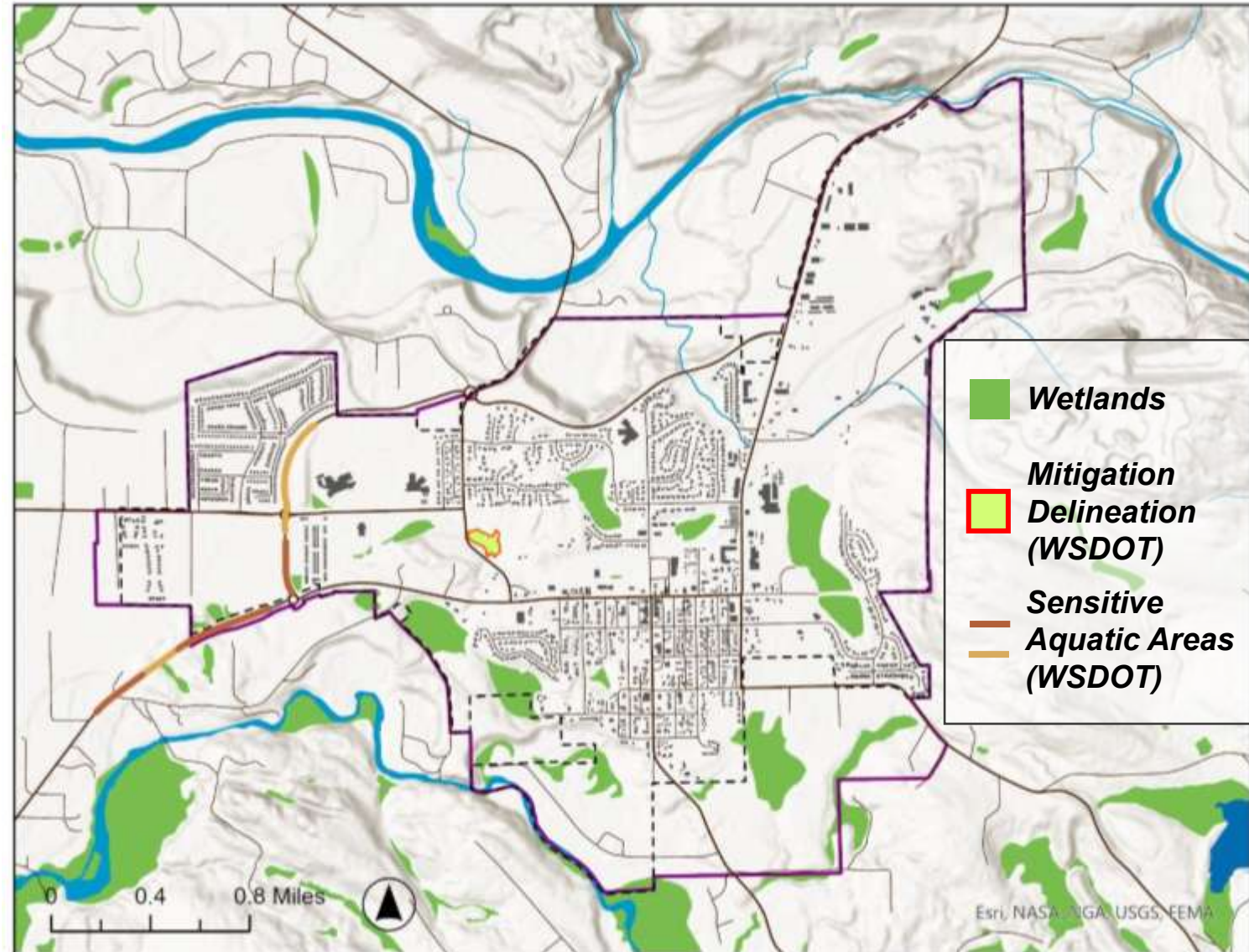



# INFRASTRUCTURE AND PUBLIC WORKS

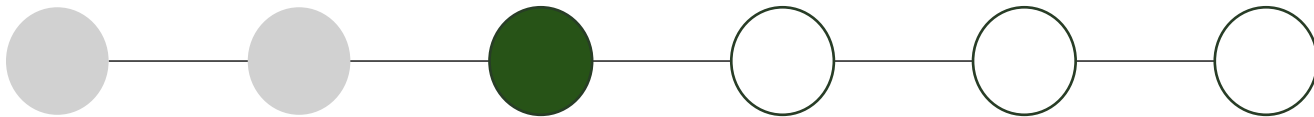

# KEY FINDINGS



1

There are **5 bridges** that support entry points into Granite Falls, all of which **support freight traffic** in and out of the city

2

Most downtown stormwater **discharges** to **Lake Gardner** before draining to the **Pilchuck River**.

3

**Snohomish County PUD** manages and operates the **potable water system** for the city. Drinking water **meets or exceeds** all government standards.

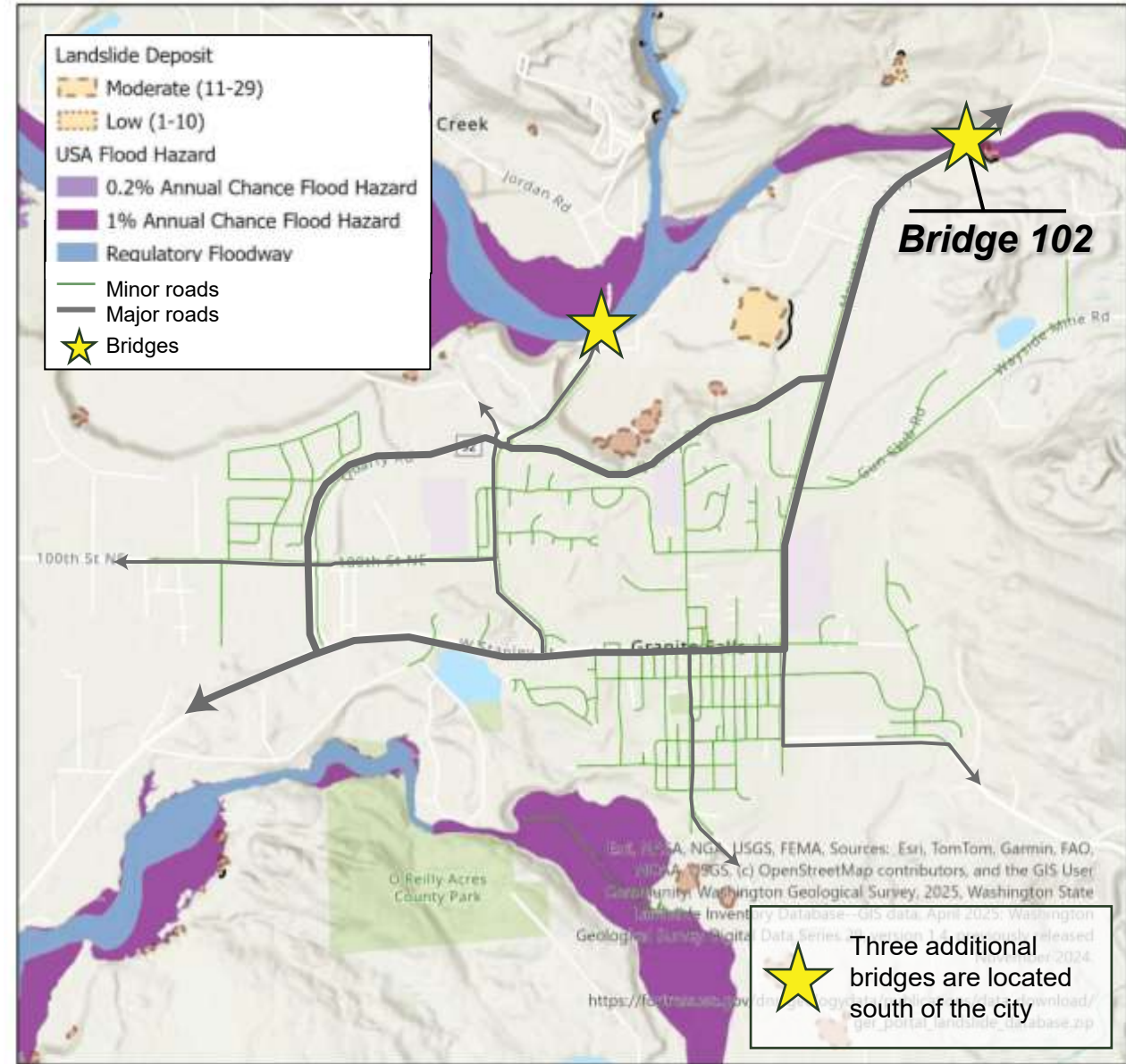



# KEY FINDINGS

1

There are **5 bridges** that support entry points into Granite Falls, all of which **support freight traffic** in and out of the city

2

Most downtown stormwater **discharges to Lake Gardner** before draining to the **Pilchuck River**.

3

**Snohomish County PUD** manages and operates the **potable water system** for the city. Drinking water **meets or exceeds** all government standards.

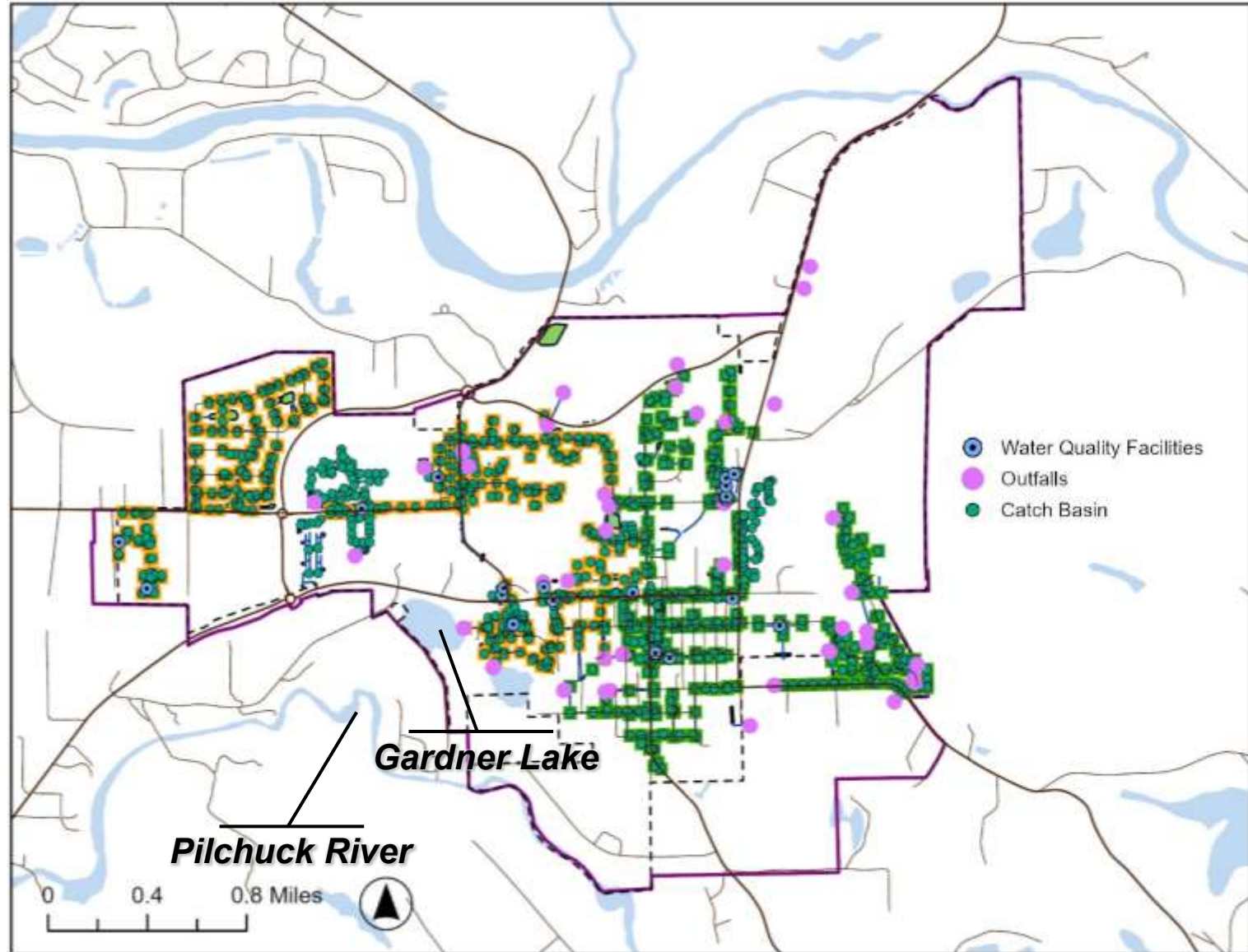



# KEY FINDINGS

1

There are **5 bridges** that support entry points into Granite Falls, all of which **support freight traffic** in and out of the city

2

Most downtown stormwater **discharges** to **Lake Gardner** before draining to the **Pilchuck River**.

3

**Snohomish County PUD** manages and operates the **potable water system** for the city. Drinking water **meets or exceeds** all government standards.

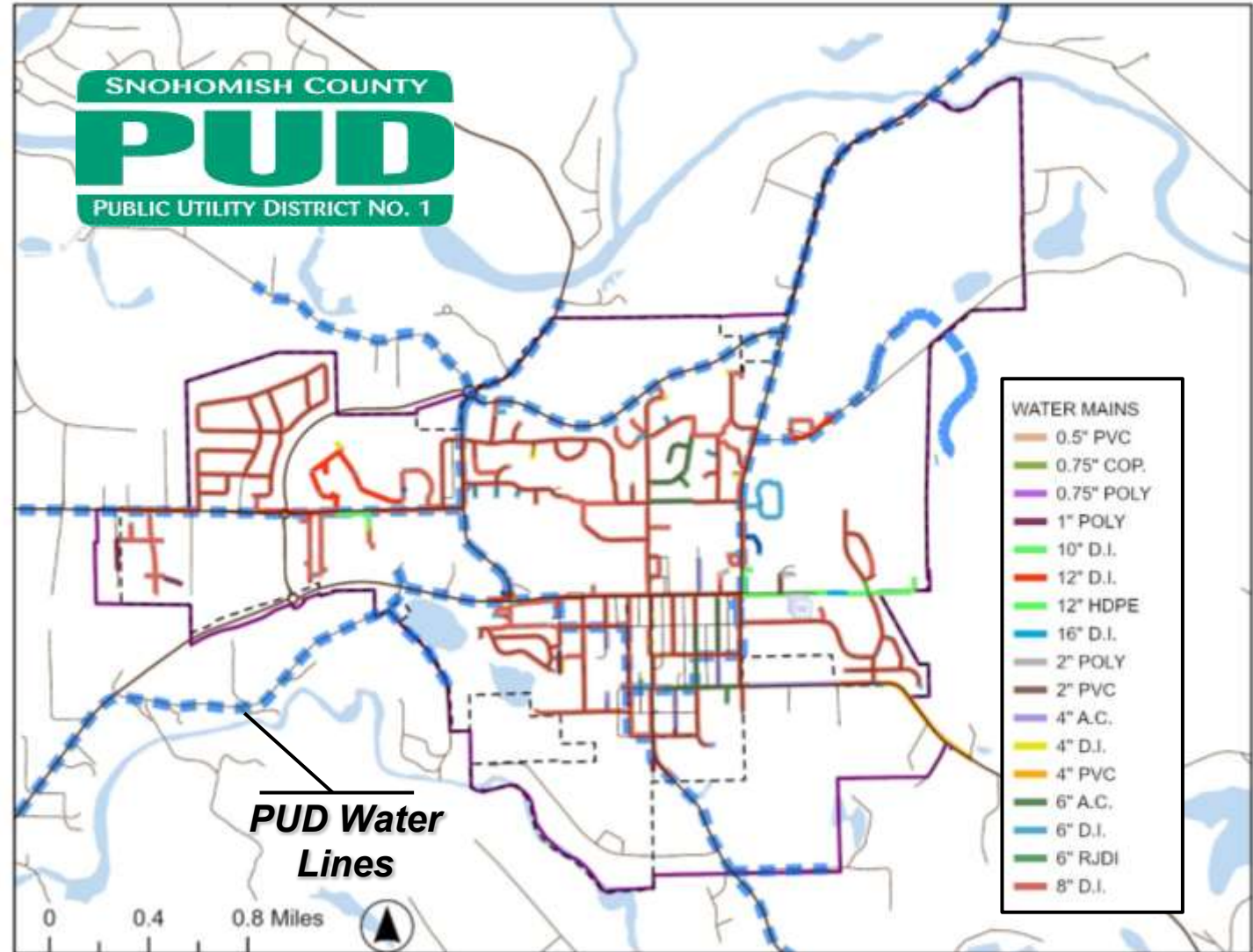



# KEY FINDINGS

4

The city's **electricity** is fed from the west to one substation, with **no redundancy**. Electrical lines are **primary overhead** within the city.

5

**Puget Sound Energy** provides natural gas power to the city, and is considered “**well-maintained and compliant**” by recent assessment

6

**Wastewater** is managed by the city, utilizing **three lift stations** and **newly constructed wastewater treatment plant**. **Housing moratorium**, due to wastewater capacity, was **lifted in Feb 2026**.

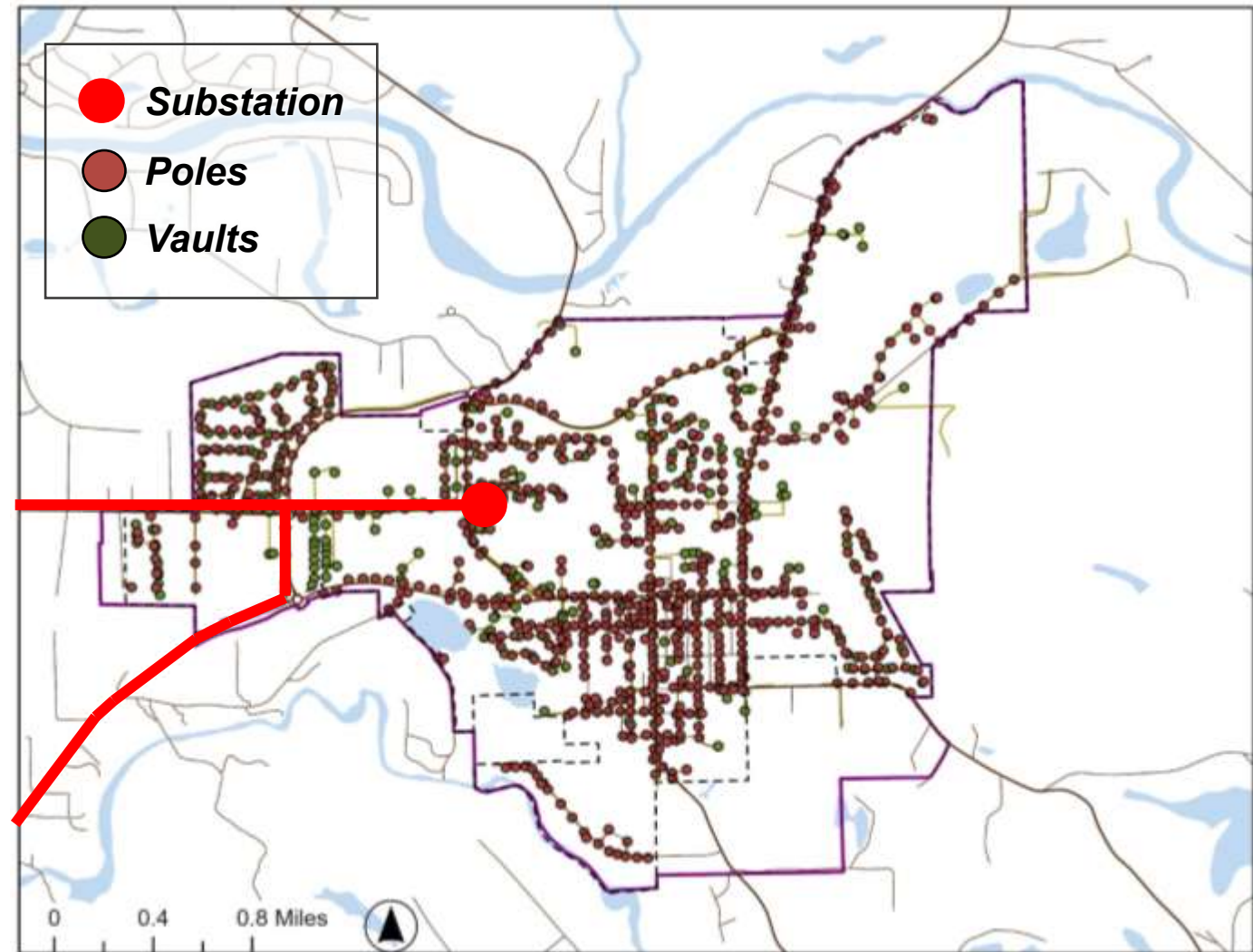

# KEY FINDINGS

4

The city's **electricity** is fed from the west to one substation, with **no redundancy**. Electrical lines are **primary overhead** within the city.

5

**Puget Sound Energy** provides natural gas power to the city and is considered **“well-maintained and compliant”** by recent assessment.

6

**Wastewater** is managed by the city, utilizing **three lift stations** and **newly constructed wastewater treatment plant**. **Housing moratorium**, due to wastewater capacity, was **lifted in Feb 2026**.



*PUGET  
SOUND  
ENERGY*



# KEY FINDINGS

4

The city's **electricity** is fed from the west to one substation, with **no redundancy**. Electrical lines are **primary overhead** within the city.

5

**Puget Sound Energy** provides natural gas power to the city and is considered "**well-maintained and compliant**" by recent assessment.

6

**Wastewater** is managed by the city, utilizing **three lift stations** and **newly constructed wastewater treatment plant**. **Housing moratorium**, due to wastewater capacity, was **lifted in Feb 2026**.

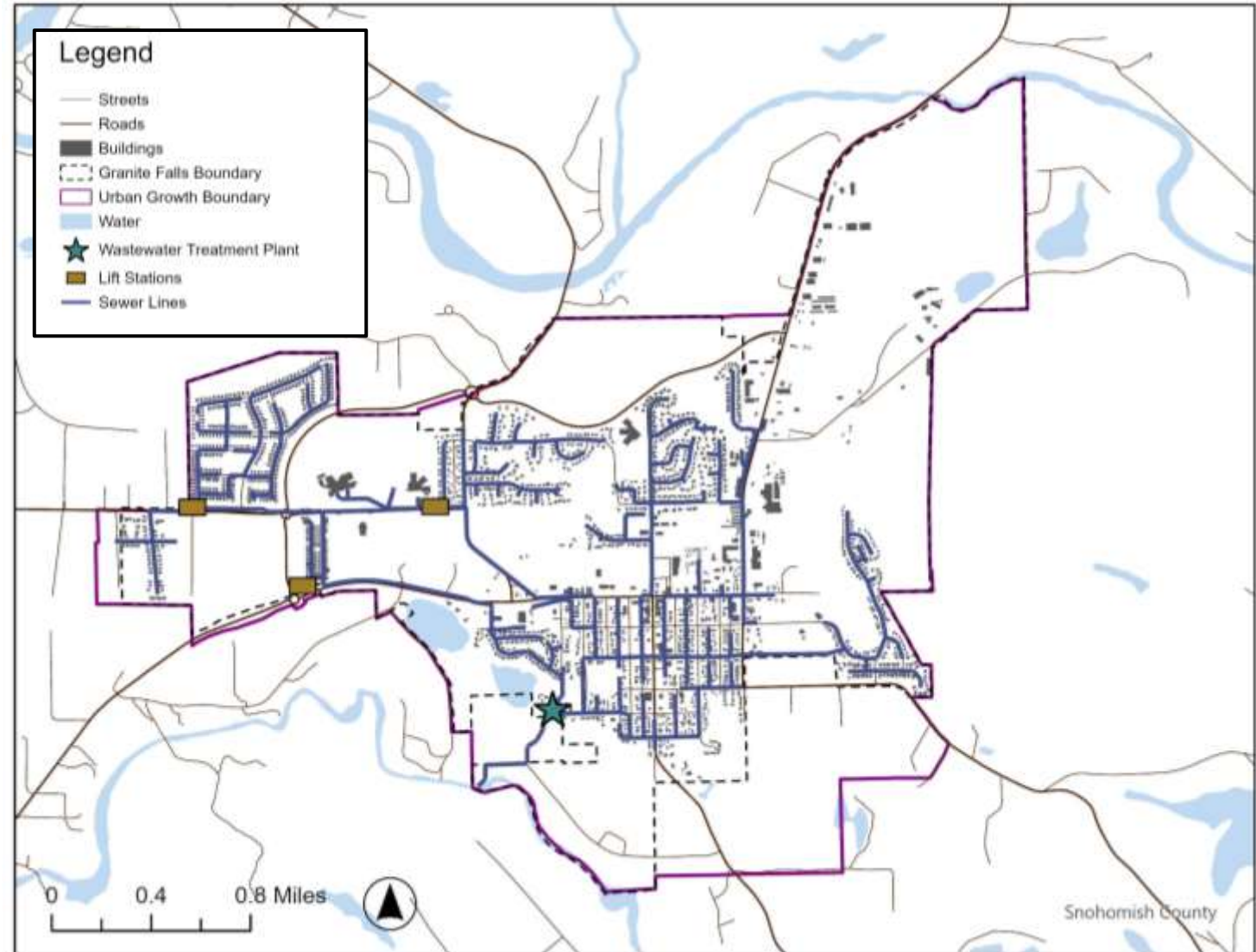

# INSIGHTS

1

**Underground utilities and damage to roads and bridges** are the primary concern during an **earthquake**. Potential to cause **loss of utilities** and **isolated communities**.

2

Key transit corridors cross **floodplain**; floods can cause **road damage** and result in **isolation** of certain communities.

3

While **landslides** are not a physical concern to roadways, additional congestion caused by landslide hazards in residential areas can **slow evacuation**.

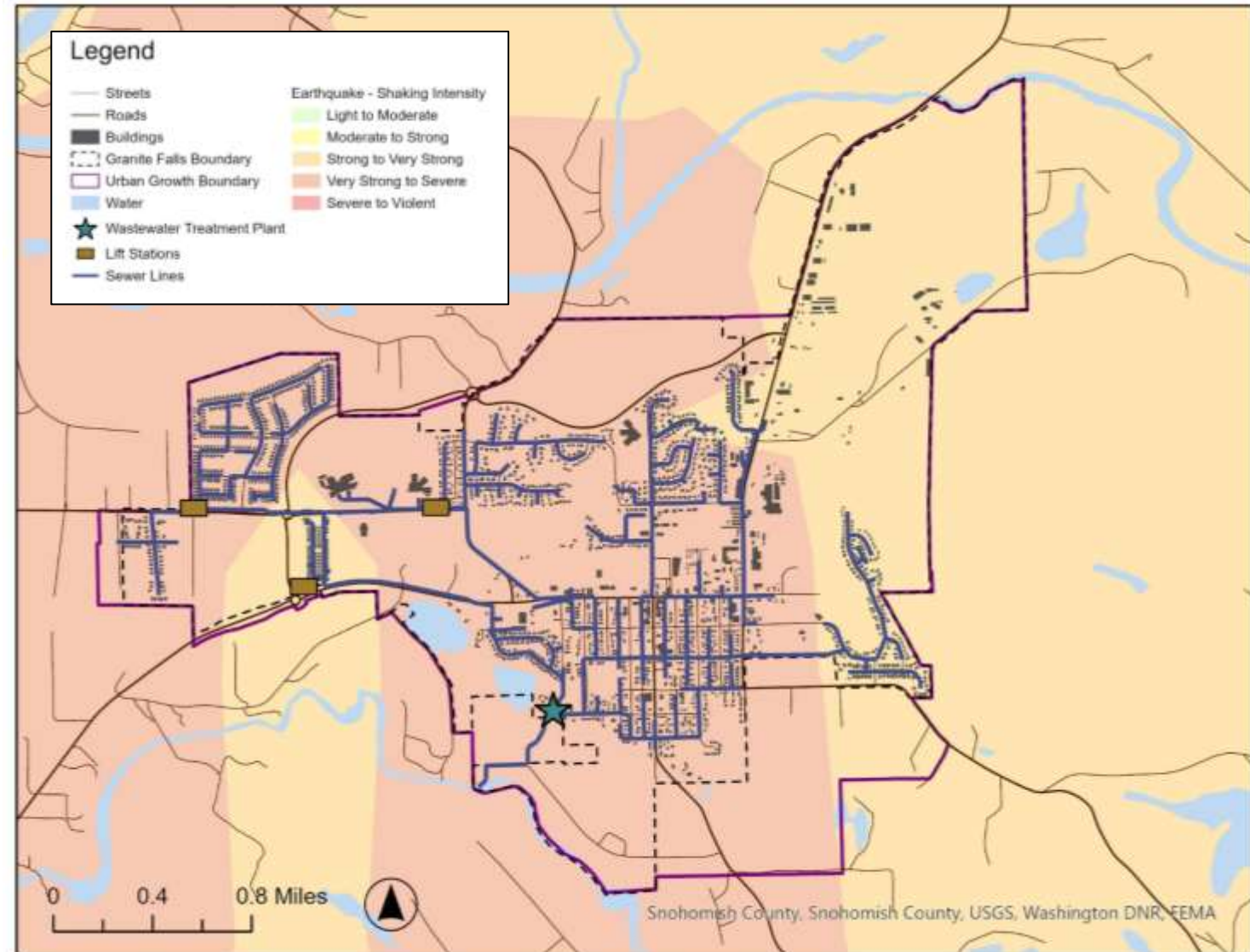



# INSIGHTS

1

Underground utilities and damage to roads and bridges are the primary concern during an earthquake. Potential to cause loss of utilities and isolated communities.

2

Key transit corridors cross floodplain; floods can cause road damage and result in isolation of certain communities.

3

While landslides are not a physical concern to roadways, additional congestion caused by landslide hazards in residential areas can slow evacuation.

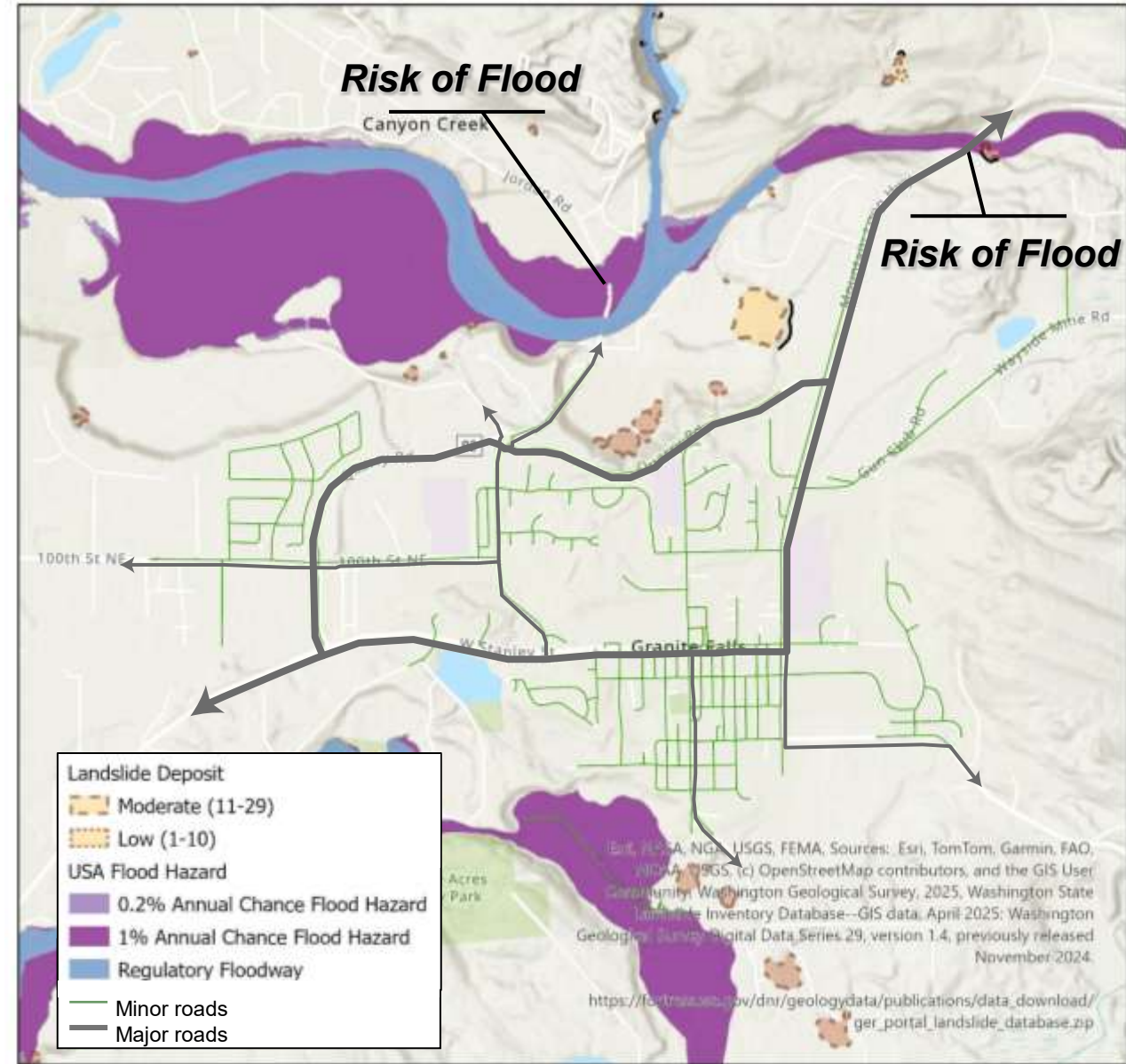



# INSIGHTS

1

Underground utilities and damage to roads and bridges are the primary concern during an earthquake. Potential to cause loss of utilities and isolated communities.

2

Key transit corridors cross floodplain; floods can cause road damage and result in isolation of certain communities.

3

While landslides are not a physical concern to roadways, additional congestion caused by landslide hazards in residential areas can slow evacuation.

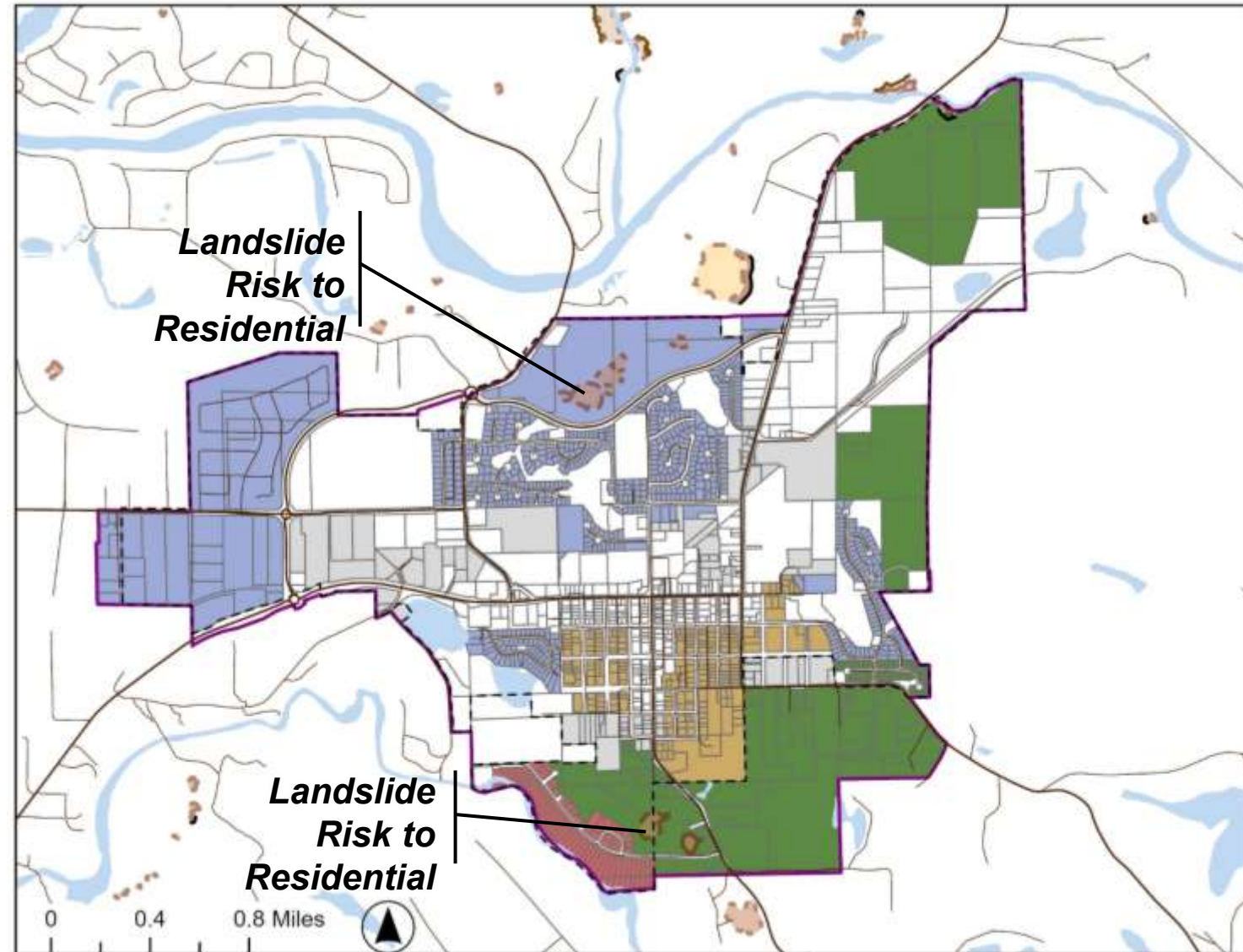

# INSIGHTS

4

**Wildfires** can cause **road closures** and **power line damage** primarily on the north and East sides of the city

5

Centrally located stormwater systems can be overwhelmed during severe rainstorms, which could cause infrastructure damage and flooding.

6

The substation is distanced from wildfire and landslide risk; **electrical power lines** present a greater concern due to risk of damage during a **severe wind event**.

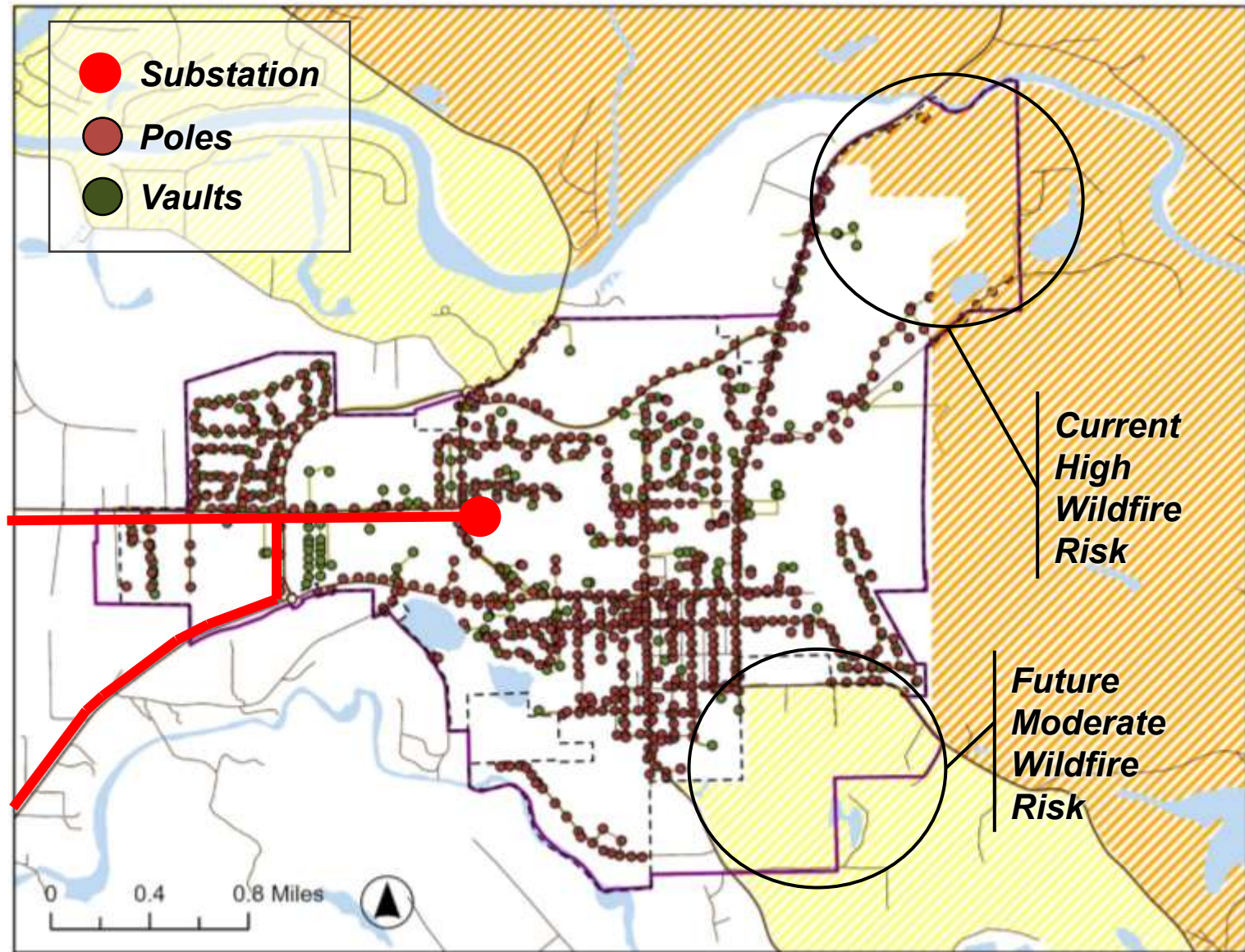



# INSIGHTS

4

Wildfires can cause road closures and power line damage primarily on the North and East sides of the city

5

Centrally located stormwater systems can be overwhelmed during severe rainstorms, which could cause infrastructure damage and flooding.

6

The substation is distanced from wildfire and landslide risk; electrical power lines present a greater concern due to risk of damage during a severe wind event.

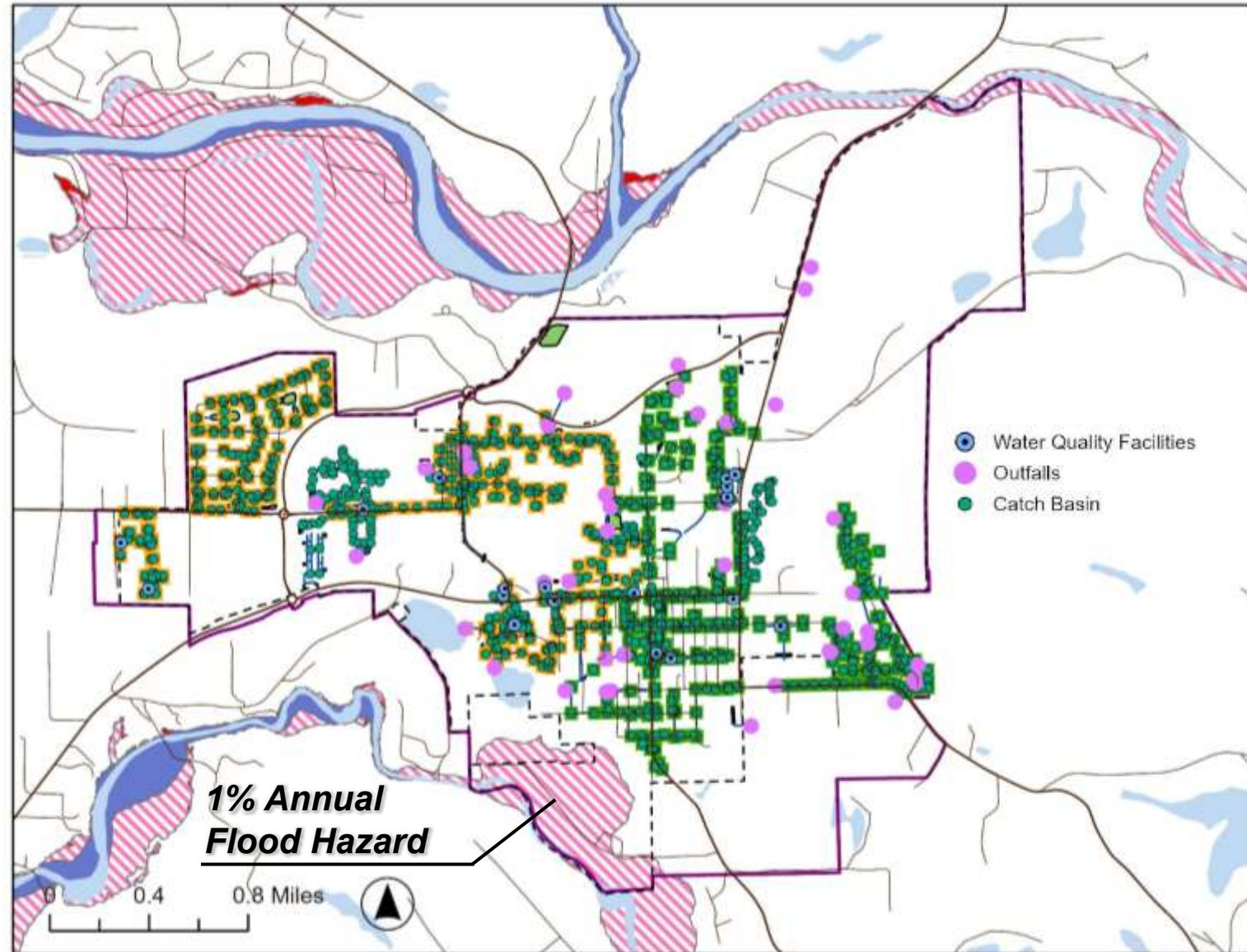



# INSIGHTS

4

Wildfires can cause road closures and power line damage primarily on the North and East sides of the city

5

Centrally located stormwater systems can be overwhelmed during severe rainstorms, which could cause infrastructure damage and flooding.

6

The substation is distanced from wildfire and landslide risk; **electrical power lines present a greater concern** due to risk of damage during a **severe wind event**.

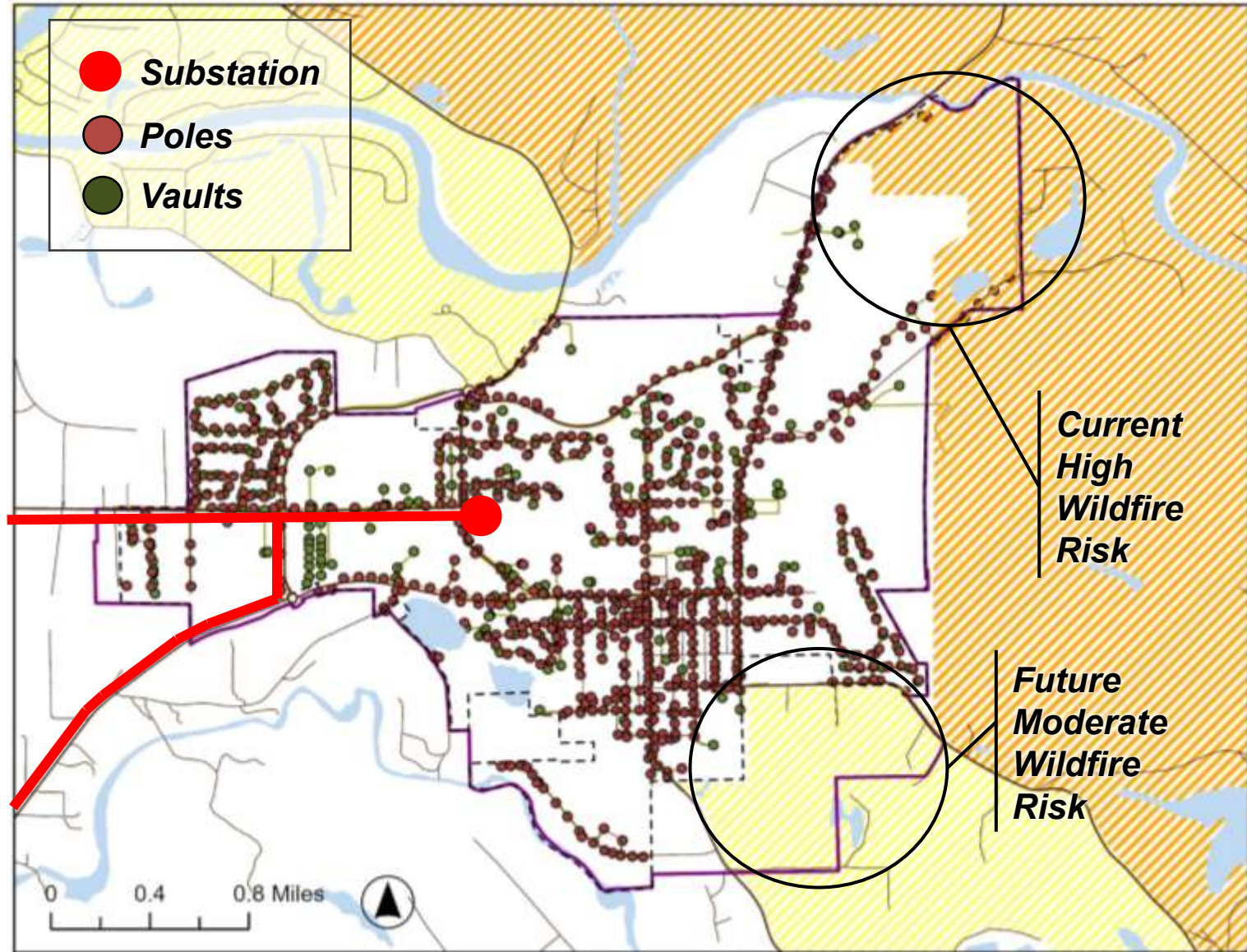

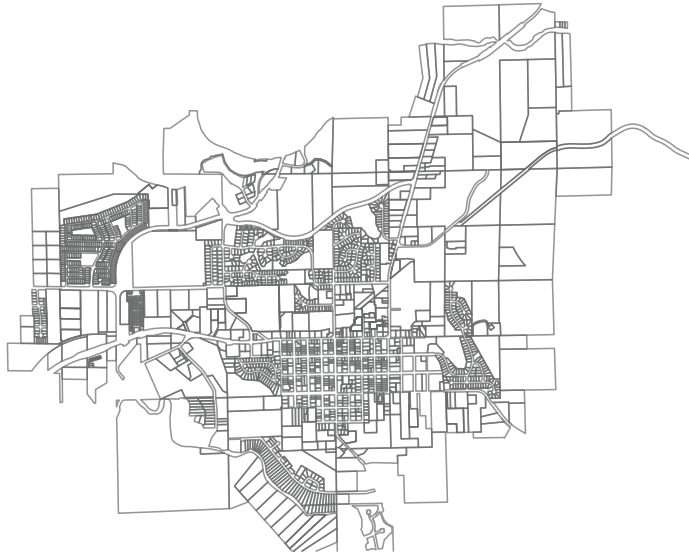

# ECONOMIC DEVELOPMENT AND HOUSING

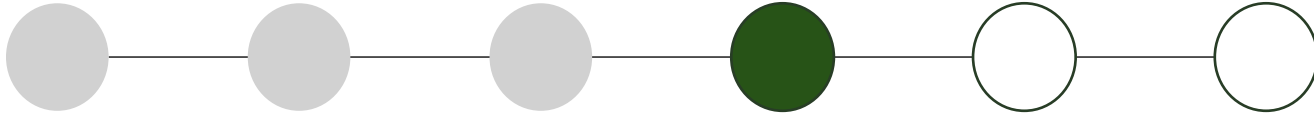

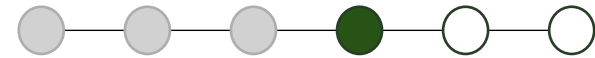

# KEY FINDINGS

1

**40% of the city's work workforce leaves the community each day (37 Min Avg commute).** The city's daytime population drops from 4,700 to 3,300 people

2

**84% of homes** are single-family homes. Rental housing is scarce and manufactured housing is primary affordable housing option. **60% of housing** was built between 1990 & 2010.

3

Risk from wildfire and earthquakes are primary concern. Wildlife Urban Interface threat to housing stock. This creates concerns over impacts to health from air quality and **isolation.**

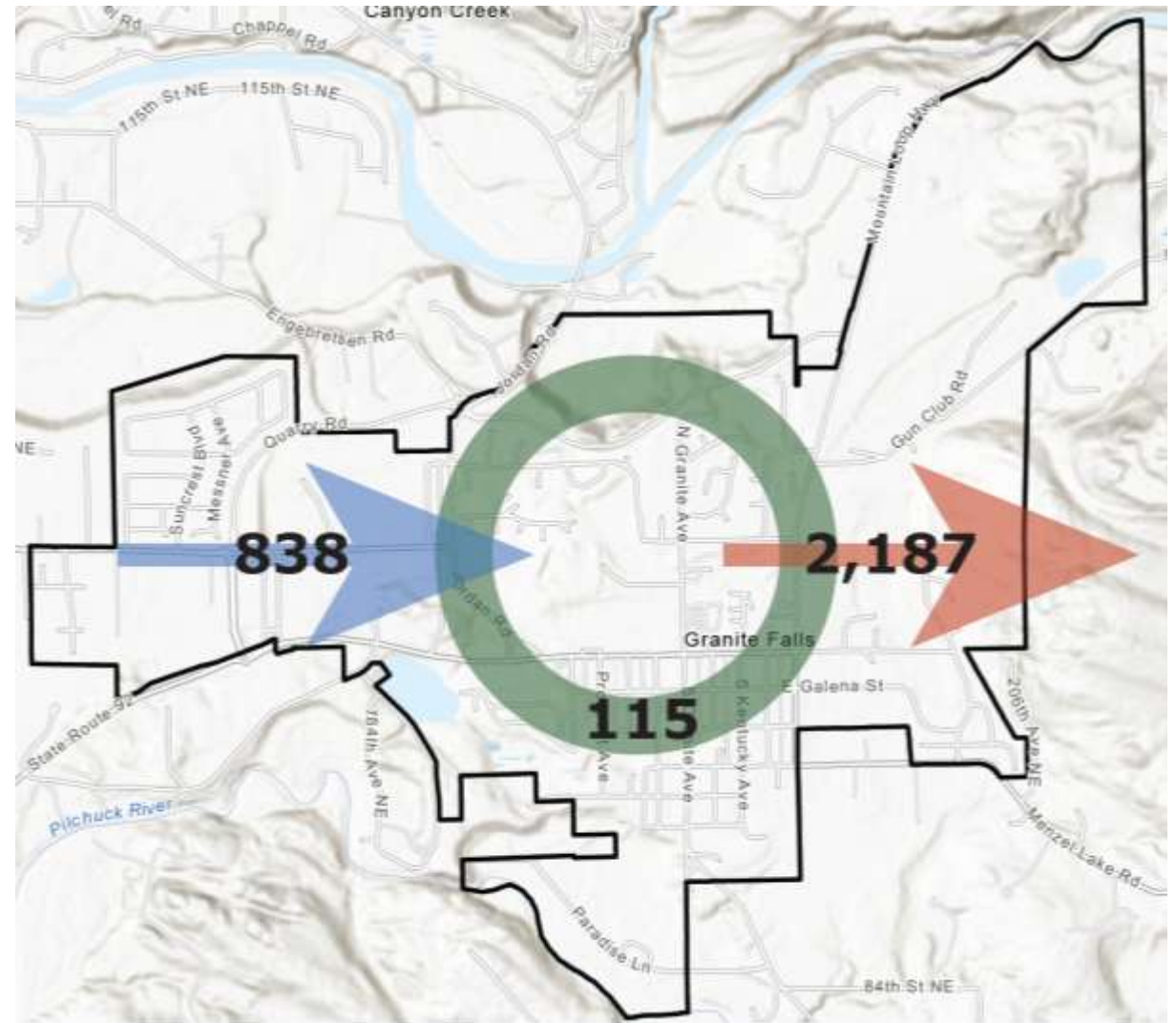

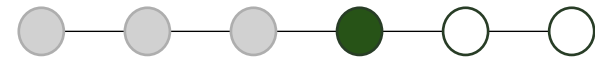

# KEY FINDINGS

Types of Housing

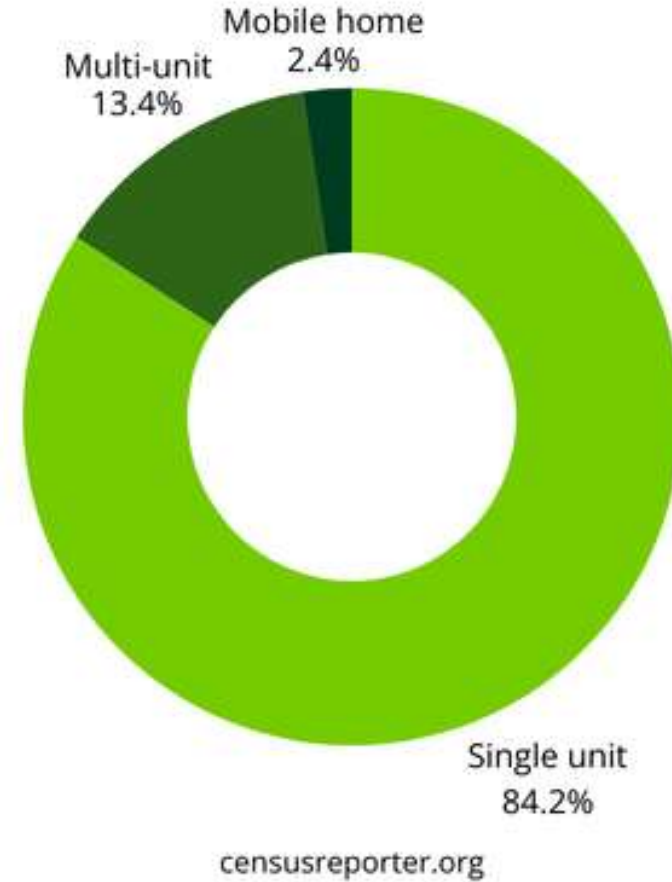

1

40% of the city's work workforce leaves the community each day (37 Min Avg commute). The city's daytime population drops from 4,700 to 3,300 people

2

**84% of homes** are single-family homes. Rental housing is scarce and manufactured housing is primary affordable housing option. **60% of housing** was built between 1990 & 2010.

3

Risk from wildfire and earthquakes are primary concern. Wildlife Urban Interface threat to housing stock. This creates concerns over impacts to health from air quality and **isolation**.

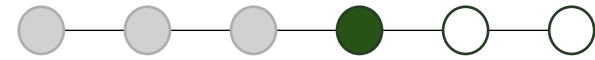

# KEY FINDINGS

1

40% of the city's work workforce leaves the community each day (37 Min Avg commute). The city's daytime population drops from 4,700 to 3,300 people

2

84% of homes are single-family homes. Rental housing is scarce and manufactured housing is primary affordable housing option. 60% of housing was built between 1990 & 2010.

3

Risk from wildfire and earthquakes are primary concern. Wildlife Urban Interface causes threat to housing stock. This creates concerns over impacts to health from air quality and **isolation**.

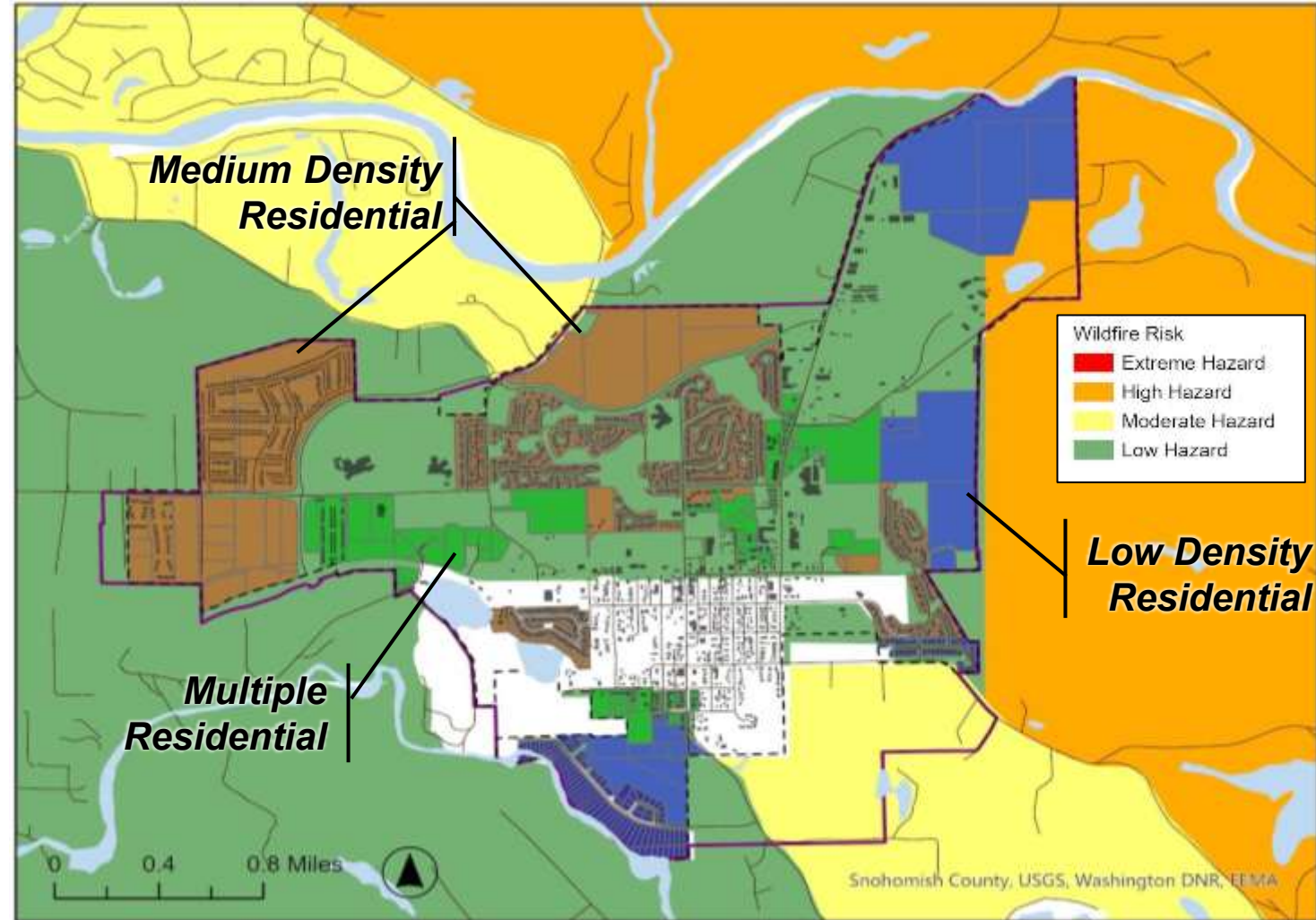

# INSIGHTS

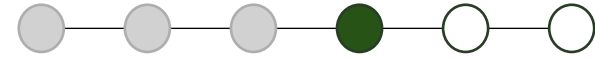

1

**Dependence on Regional Employment Centers.** Creates pressure on resources and increases reliance on critical infrastructure.

2

**Economic and Social Isolation.** Potential impacts could be supply and inventory shortages due to blocked transportation routes. Current development strategies do not include provisions for mitigating hazards.

3

**Uneven vulnerability.** Housing types and conditions differ within residential areas. Older homes may require more retrofitting and be more vulnerable to hazards. **Socially vulnerable communities will need greater support for hazard recovery.**



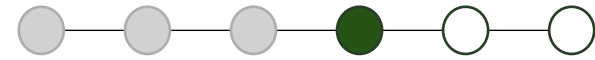

# INSIGHTS

1

**Dependence on Regional Employment Centers.** Creates pressure on resources and increases reliance on critical infrastructure.

2

**Economic and Social Isolation.** Potential impacts could be supply and inventory shortages due to blocked transportation routes. Current development strategies do not include provisions for mitigating hazards.

3

**Uneven vulnerability.** Housing types and conditions differ within residential areas. Older homes may require more retrofitting and be more vulnerable to hazards. **Socially vulnerable communities will need greater support for hazard recovery.**



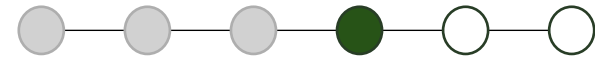

# INSIGHTS

1

**Dependence on Regional Employment Centers.** Creates pressure on resources and increases reliance on critical infrastructure.

2

**Economic and Social Isolation.** Potential impacts could be supply and inventory shortages due to blocked transportation routes. Current development strategies do not include provisions for mitigating hazards.

3

**Uneven vulnerability.** Housing types and conditions differ within residential areas. Older homes may require more retrofitting and be more vulnerable to hazards. **Socially vulnerable communities will need greater support for hazard recovery.**

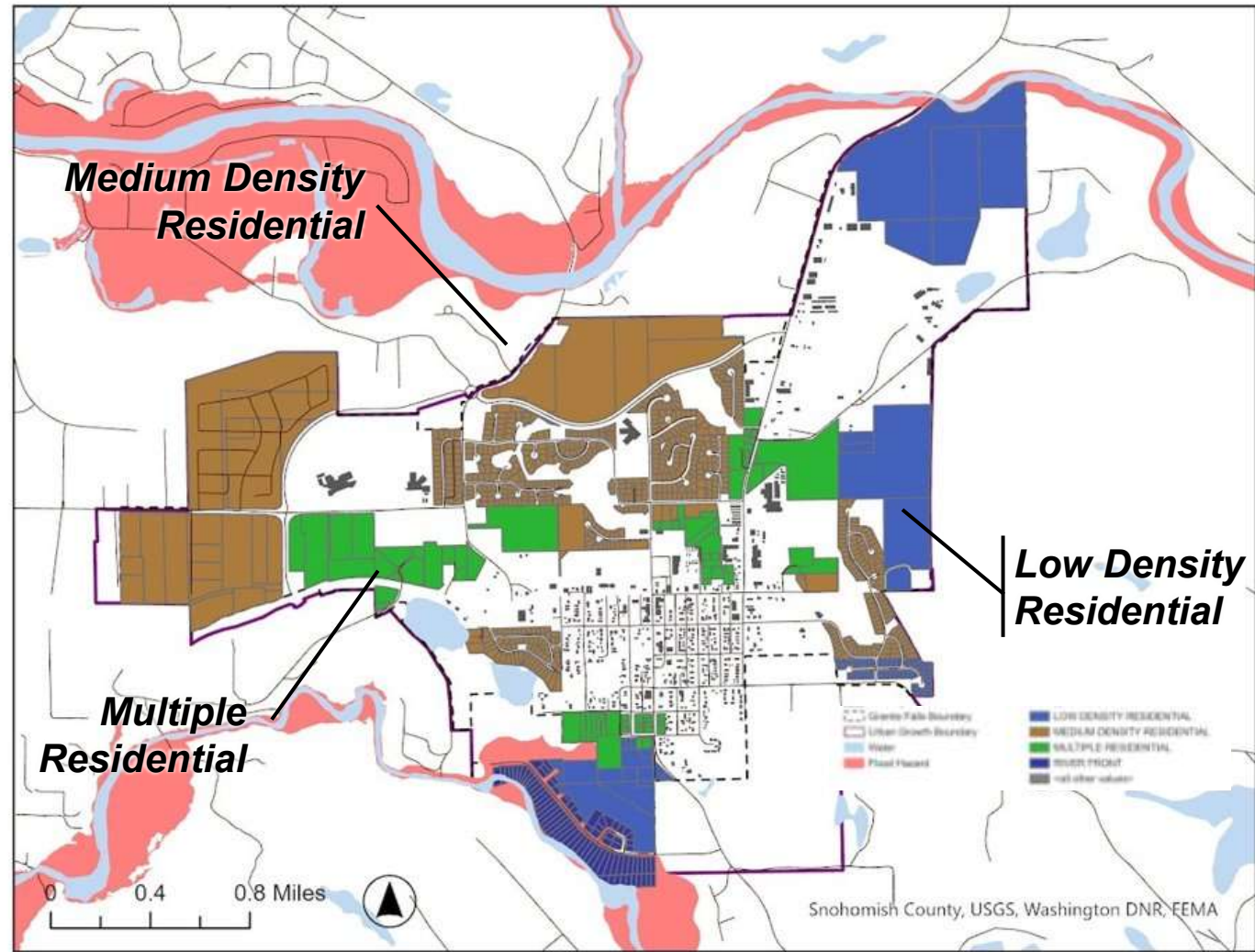



# PUBLIC, HEALTH, AND CULTURAL FACILITIES

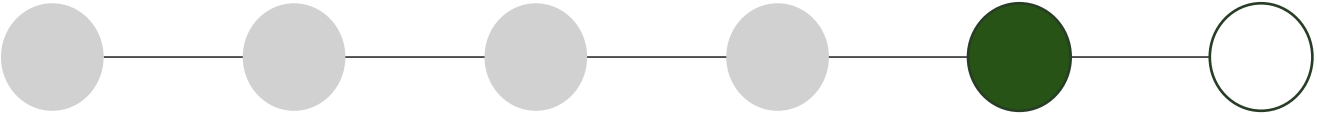



# KEY FINDINGS

1

**Emergency response depends heavily on mutual aid**, which may be limited by single access corridors.

2

Schools and daycares **concentrate vulnerable populations** in facilities with varying seismic resilience.

3

Granite Falls has **no hospital or urgent care** within city limits.

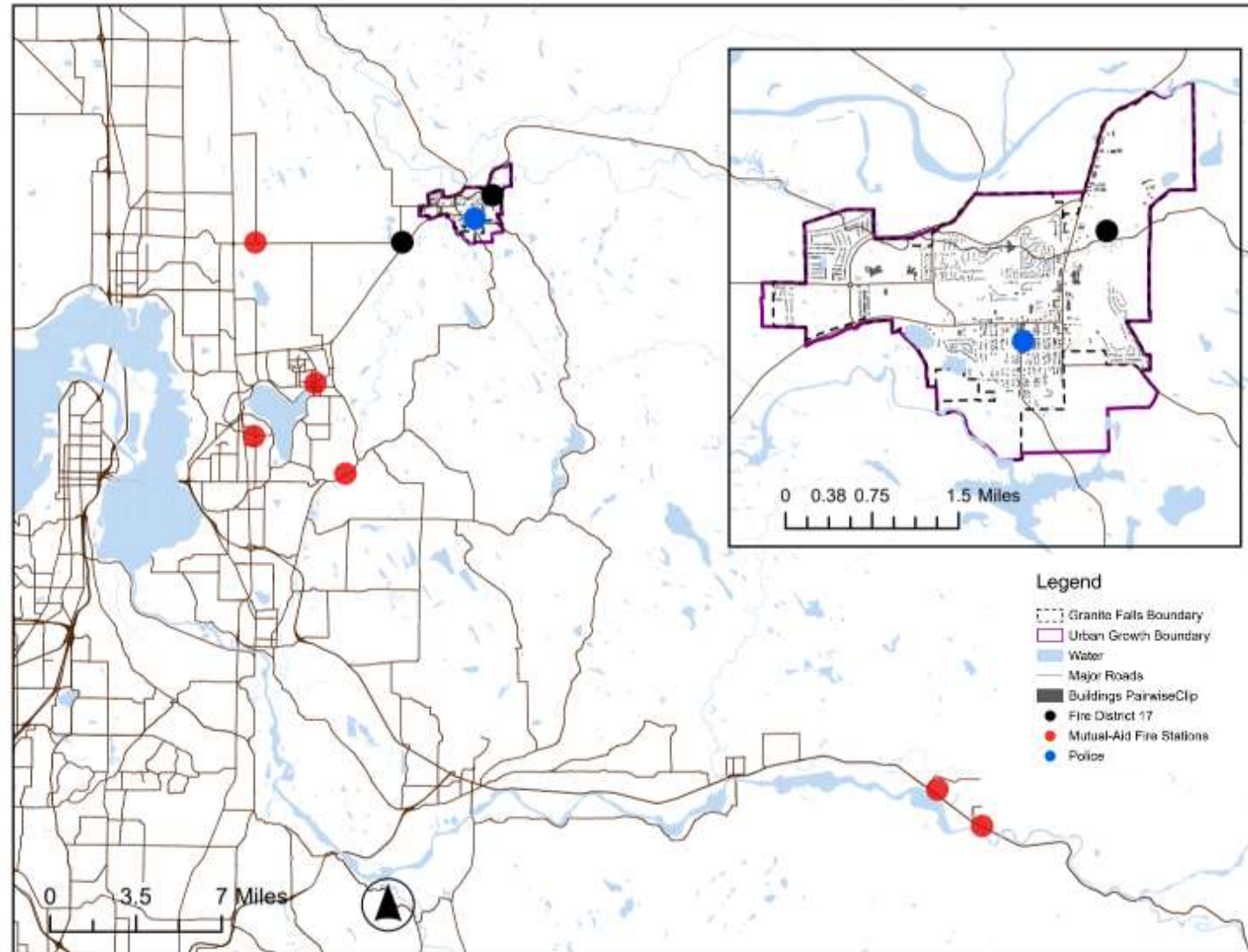



# KEY FINDINGS

1

Emergency response depends heavily on mutual aid, which may be limited by single access corridors.

2

Schools and daycares **concentrate vulnerable populations** in facilities with varying seismic resilience.

3

Granite Falls has **no hospital or urgent care** within city limits.

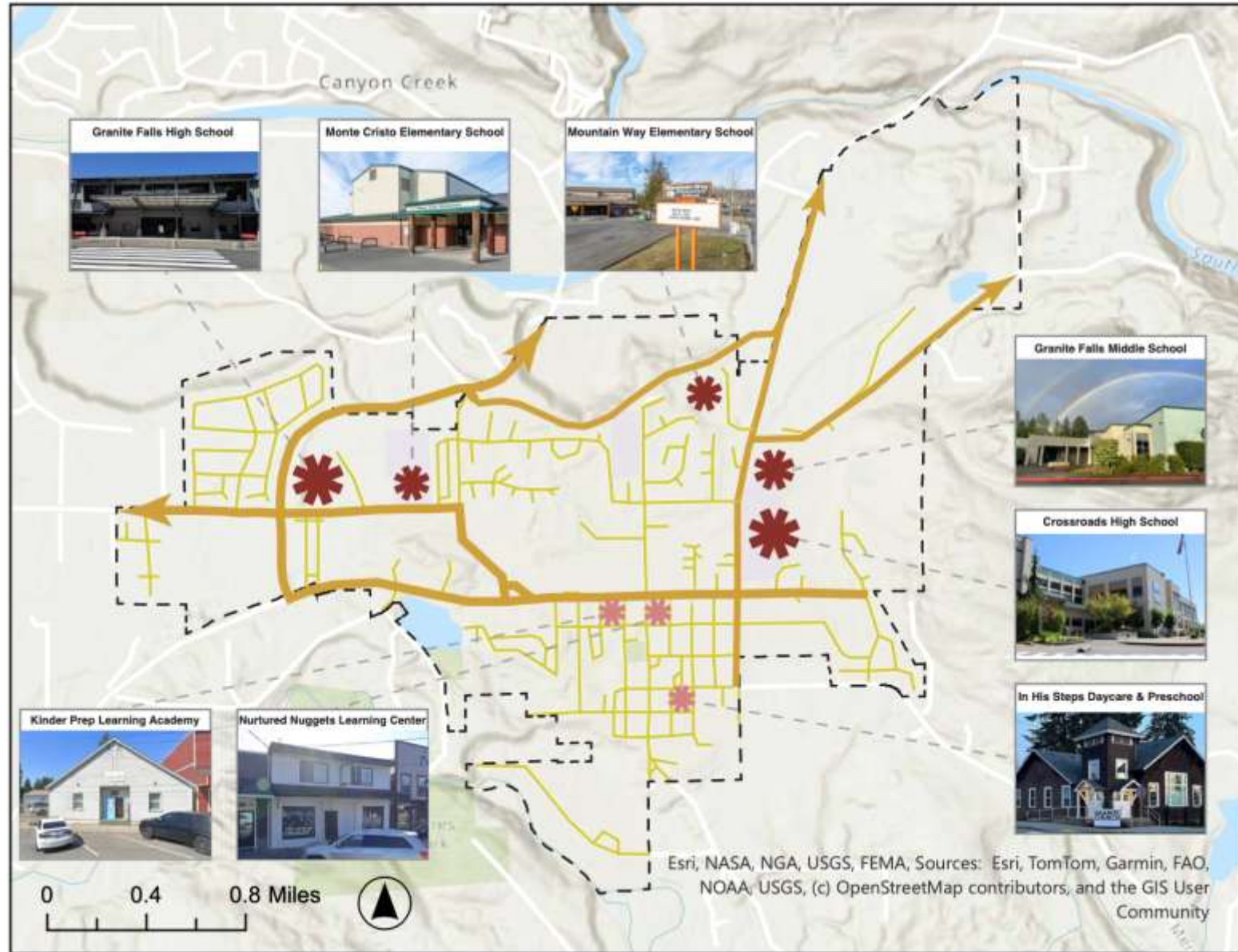



# KEY FINDINGS

1

Emergency response depends heavily on mutual aid, which may be limited by single access corridors.

2

Schools and daycares concentrate vulnerable populations in facilities with varying seismic resilience.

3

Granite Falls has **no hospital or urgent care** within city limits.

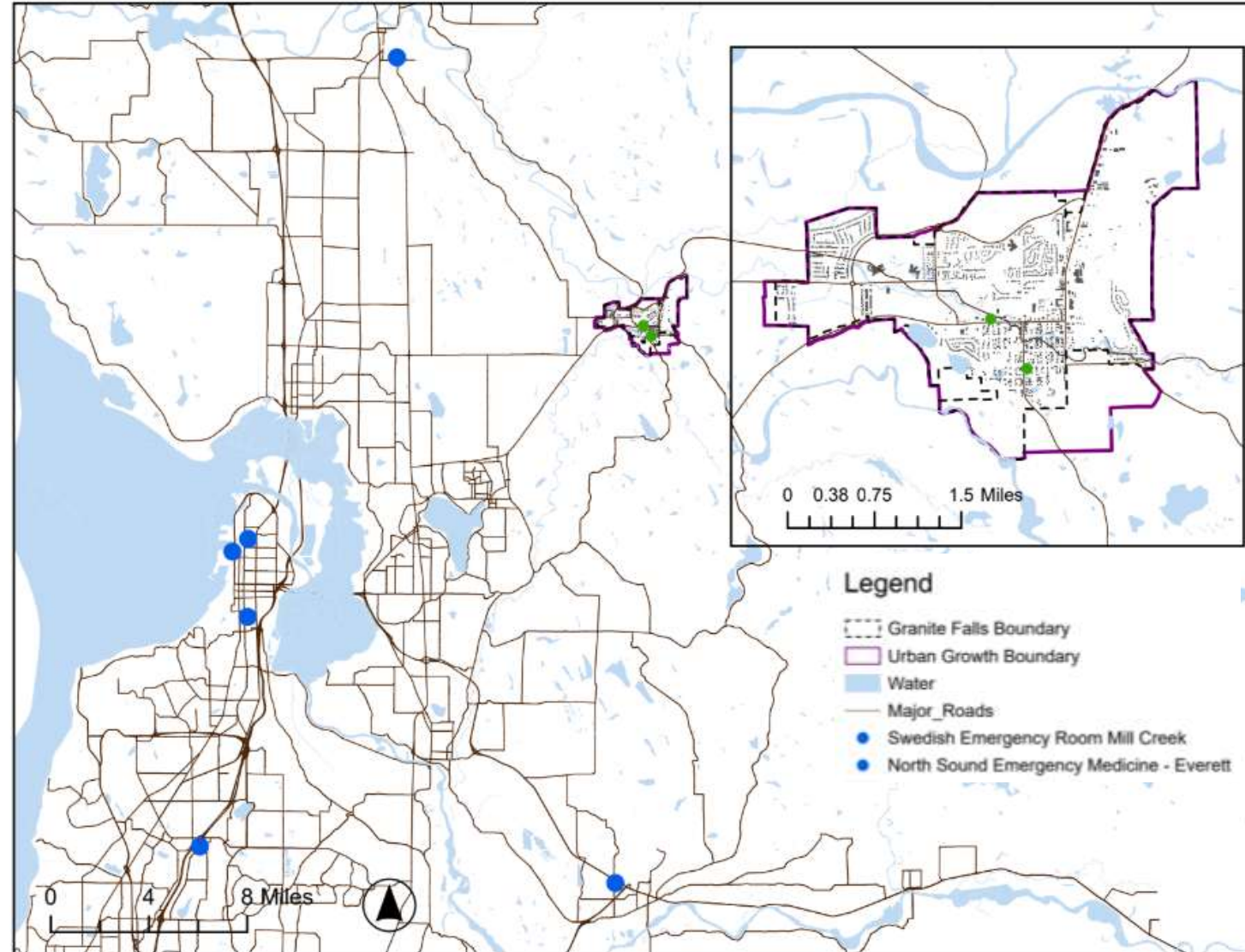



# INSIGHTS

1

Single fire station and contract law enforcement **create response capacity constraints** during simultaneous incidents.

2

Limited redundancy in human and cultural facilities **creates vulnerability for essential functions.**

3

Limited local emergency medical capacity **increases reliance on distant facilities during hazards.**





# INSIGHTS

1

Single fire station and contract law enforcement **create response capacity constraints** during simultaneous incidents.

2

Limited redundancy in human and cultural facilities **creates vulnerability for essential functions.**

3

Limited local emergency medical capacity **increases reliance on distant facilities during hazards.**





# INSIGHTS

1

Single fire station and contract law enforcement **create response capacity constraints during simultaneous incidents.**

2

Limited redundancy in human and cultural facilities **creates vulnerability for essential functions.**

3

Limited local emergency medical capacity **increases reliance on distant facilities during hazards.**

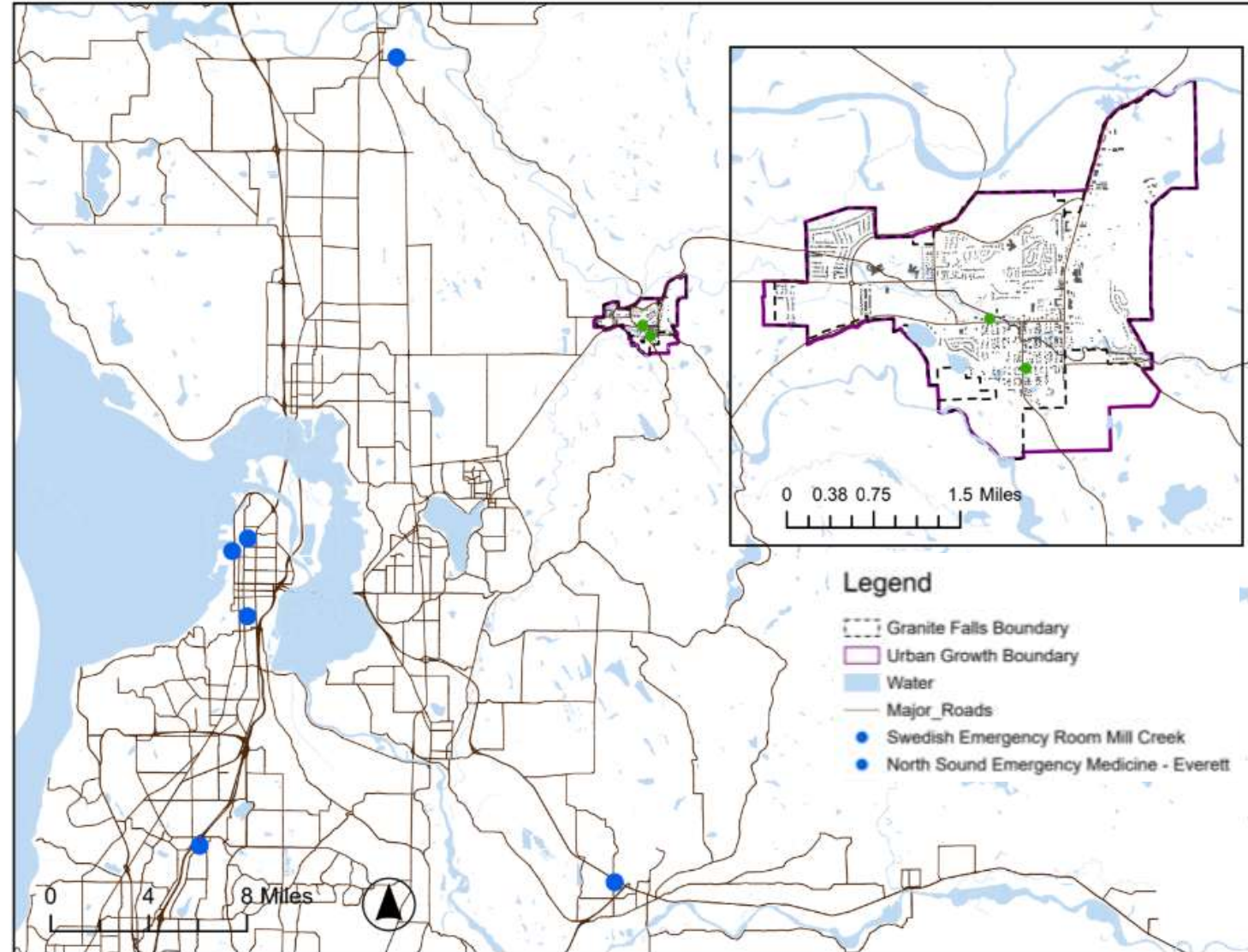

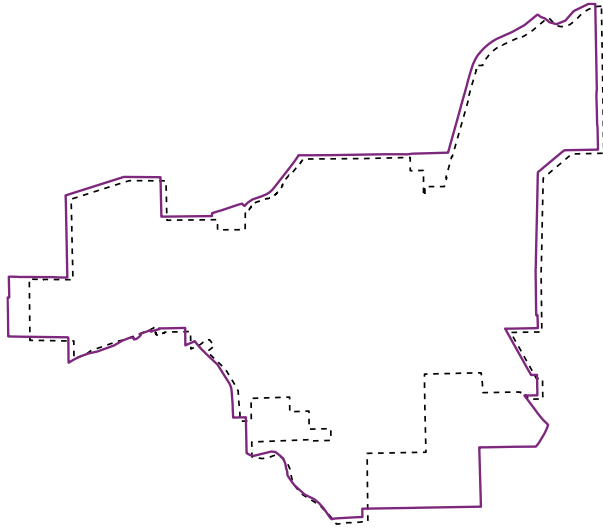

# PROJECT ROADMAP AND Q+A



# PROJECT ROAD MAP

## Phase 1

## Phase 2

## Phase 3



# PROJECT ROAD MAP

YOU ARE HERE



Phase 1

Phase 2

Phase 3

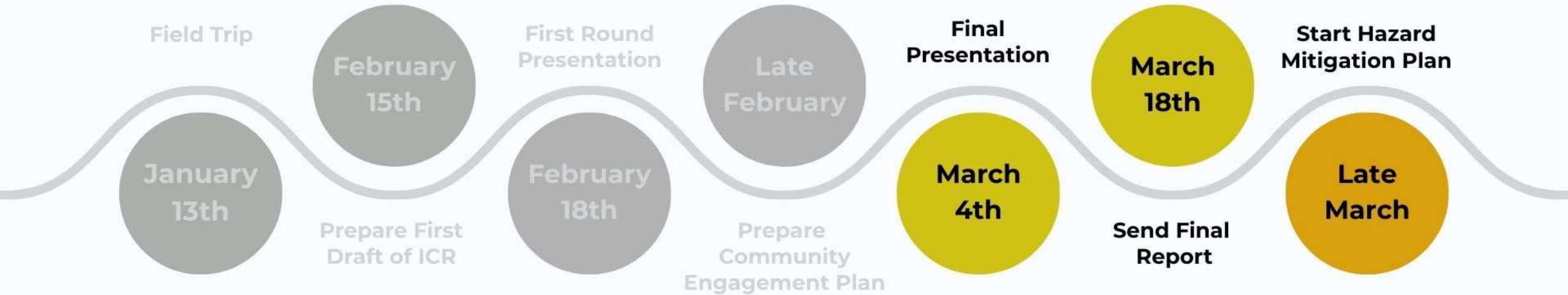

# Questions?

**Representative:** Caroline Webster | [cweb40@uw.edu](mailto:cweb40@uw.edu)





## CITY COUNCIL AGENDA BILL

**Subject:** 7.c.

**Originating Dept.:** City Council

**Action Recommended:** Discussion only

**Approval(s):**

**Meeting Date:** March 4, 2026

**Date Submitted:**

**Exhibit(s):**

1. SB 6002 Update

---

**Budgeted Amount:** \$0.00

**BARS Code:** 521 20 49 01

---

### **Summary Statement:**

The presentation provides an update on ESSB 6002, a bill currently before the 2026 Legislature, and examines its potential effects on the City's Automated License Plate Reader (ALPR) program operated by Flock Safety. The bill introduces statewide privacy protections for drivers, including strict rules on how ALPR data is used, stored, shared, and overseen. It takes effect immediately due to an emergency clause. Key points include PRR exemptions, a 21-day limit on data retention, mandatory system registration with the Attorney General within 180 days, local policy adoption by December 1, 2027, annual public reports, and two years of audit logs. The bill also limits ALPR data use, bans uses related to immigration enforcement, healthcare, and monitoring protected activities, and establishes new penalties and private rights of action for violations.

---

### **Background:**

Through the Snohomish County Sheriff's Department, the City operates seven Flock Safety ALPR cameras for safety and investigation, with cloud storage and vendor-managed infrastructure. The passage of SB 6002 would provide some exemptions from Public Records Requests, require a gap analysis to ensure compliance with data retention, audit logging, data control, and placement restrictions, and require a review of data-sharing practices.

The City will likely have two options: fully comply with the bill, involving policy (in coordination with SnoCo), training, and legal efforts, or suspend the system to avoid liability or losing a key investigative tool.

The City will continue to monitor legislative progress, prepare a compliance plan if the legislation is passed, engage with Flock Safety for updates, and have future policy discussions with the Snohomish County Sheriff.

---

**Recommended Motion:**

Discussion only

# SB 6002: Driver Privacy Protections

Legislative Update & Compliance Review

City of Granite Falls ALPR Program

City Manager • March 4, 2026

## Executive Summary

- ESSB 6002 passed Senate 40-9 on February 4, 2026
- Currently in House Civil Rights & Judiciary Committee
- Executive session scheduled February 24, 2026
- If enacted, takes effect immediately (emergency clause)

## Current Legislative Status

- Senate passage: Bipartisan 40-9 vote (Feb 4)
- House public hearing: February 18, 2026
- House executive session: February 24, 2026
- Session deadline: March 12, 2026

## Critical Compliance Requirements (1 of 2)

- **21-day data retention limit** (down from original 72 hours)
- **180-day registration** with Attorney General after effective date
- **Policy adoption** by December 1, 2027 (AG model policies by July 1, 2027)
- **Annual public reporting** requirements

## Critical Compliance Requirements (2 of 2)

- **Audit trail retention:** Two (2) years of all system access logs
- **Annual internal audit** of ALPR system access and compliance
- **Watch list updates:** At least every 24 hours
- **Vendor controls:** Prevent unauthorized data sharing

## Permitted ALPR Uses

- Compare with state/federal watch lists (DOL, NCIC, missing persons)
  - DOL watch list, is a list of plates generated from DOL-managed data (e.g., stolen vehicles, suspended registrations, vehicles flagged for specific statutory purposes) that law enforcement or an authorized agency uses as a hot list for ALPR hits.
  - An NCIC watch list in the ALPR setting is a subset of NCIC plate records (for example, stolen vehicles, felony warrants, missing/endangered persons) exported or queried so that an ALPR hit can alert officers when a scanned plate matches one of those entries.
- Felony investigations (stolen vehicles, outstanding warrants, missing persons)
- Parking enforcement (time restrictions, impound watch lists)

## Prohibited ALPR Uses

- Immigration investigation or enforcement
- Tracking protected health care services
  - defined in RCW 7.115 as gender-affirming treatment and reproductive health care that are lawful in Washington.
- Monitoring constitutionally protected activities
  - agencies cannot build watch lists or conduct ALPR-based surveillance aimed at identifying who attended a demonstration, who regularly parks near a protest site, or similar pattern-of-life monitoring of lawful speech or association.
- Camera placement near schools, places of worship, courts, food banks
  - no existing Flock cameras are pointed along the primary ingress/egress to schools, churches, the local court, or food bank.

## Data Sharing Restrictions

- Prohibited from selling, leasing, or renting ALPR data
- Limited sharing with authorized state/local agencies only
- Third-party vendor access restricted to contracted services
- Public records exemption (except anonymized research data)
  - Removes or irreversibly transforms all direct and indirect identifiers (names, full dates of birth, addresses, phone numbers, medical record numbers, precise geolocation, etc.) and only keeps aggregated fields like age range, general region (e.g., “Western WA”), category, and research type. Researchers then analyze patterns.

# Enforcement and Penalties

- **Criminal:** Gross misdemeanor for willful unauthorized access or data misuse
- **Civil liability:** Private right of action with monetary damages and attorneys' fees
- **Exclusionary rule:** Data obtained in violation inadmissible in court

# Civil Liability Risk Assessment

Section 12 creates exposure:

- Private individuals can sue for violations
  - A resident whose vehicle plate was captured near a church, school, or foodbank
  - Someone whose plate data was retained beyond 21 days
  - An individual whose data was shared improperly with federal immigration authorities
  - A person tracked while attending a protest or religious service
- Equitable, declaratory, and injunctive relief available
- Monetary damages recoverable
- Prevailing plaintiffs awarded attorneys' fees and costs

# Granite Falls Current Status

- **System:** Seven (7) Flock Safety ALPR cameras operational
- **Vendor:** Flock Safety (cloud-based system)
- **Gap analysis needed:** Current practices vs. SB 6002 requirements

## Immediate Action Items (If Bill Passes)

- Register system with Attorney General within 180 days
- Audit current data retention settings (adjust to 21-day limit)
- Implement comprehensive audit trail logging
- Review Flock contract for vendor compliance provisions
  - Check data-retention clauses to confirm the City (not Flock) controls the retention period
  - Review data-sharing and ownership language to verify that:
    - ✓ The City owns all “Customer Data” and Flock is a processor only.
    - ✓ Flock cannot share data with third parties (including federal agencies) except our discretion.
    - ✓ Confirm audit-log and access-control capabilities in the contract/SOW (e.g., ability to retain and export two years of access logs, role-based access, and user authentication.
    - ✓ Scan for public-records and subpoena/ICE language to ensure nothing obligates Flock to respond directly to subpoenas or federal requests without routing them through the City.

## Short-Term Actions (Within 6 Months)

- Await AG model policies (due July 1, 2027)
- Draft preliminary ALPR policy aligned with statute
- Document training procedures for system users
- Verify camera locations comply (no prohibited sites)

## Long-Term Compliance (By Dec 1, 2027)

- Adopt formal policy consistent with AG model policies
- Establish annual internal audit procedures
- Create annual public reporting framework
- Implement public awareness measures

# Risk Mitigation Options (1 of 2)

## Option 1: Full Compliance

- **Pros:** Maintains public safety tool, demonstrates good faith
- **Cons:** Administrative burden, ongoing reporting requirements

## Risk Mitigation Options (2 of 2)

### Option 2: System Suspension

- **Pros:** Eliminates liability exposure, reduces administrative costs
- **Cons:** Loss of investigative tool, sunk investment costs

# Vendor Coordination Required

Key discussion points with Flock Safety:

- Technical controls preventing unauthorized sharing
- Data retention configuration (21-day limit)
- Audit trail data access and export capabilities

# Budget Considerations

- Staff time for policy development and annual audits
- Annual reporting preparation and publication
- Potential contract amendments with Flock Safety
- Legal review of compliance framework

## Recommended Council Actions

- Monitor House action through March 12 session deadline
- Direct staff to prepare compliance implementation plan
- Authorize City Manager to engage with Flock Safety
- Schedule policy discussion after AG model policies issued

# Key Compliance Timeline

- **Immediate:** System registration within 180 days of enactment
- **July 1, 2027:** AG publishes model policies
- **December 1, 2027:** Adopt policies, begin annual reporting
- **Ongoing:** Annual audits and public reports

# Questions & Discussion

City Manager available for follow-up



## CITY COUNCIL AGENDA BILL

**Subject:** 7.d.

**Originating Dept.:** City Manager

**Action Recommended:** Discussion only    **Approval(s):**

**Meeting Date:** March 4, 2026

**Date Submitted:**

**Exhibit(s):**

1. Council Size Discussion

---

**Budgeted Amount:** \$21,131

**BARS Code:** 511 60 10 00 Salaries - Council

511 60 20 00 Benefits - Council

---

### Summary Statement:

This presentation discusses two options for expanding the City Council from five to seven members under RCW 35A.13.010. The current population range (2,500-5,000) gives the Council discretion to expand voluntarily or wait until the population reaches 5,000, when expansion becomes mandatory.

---

### Background:

With a current population of 4,775, the City of Granite Falls operates under a council-manager system with a five-member council. According to state law, population growth will require expanding the council to seven members once the city has a population of at least 5,000, either proactively or upon reaching that threshold. Two options are considered: expanding now with associated costs and procedural steps, or waiting until the population meets the threshold for mandatory expansion. The fiscal impact involves annual costs of approximately \$6,908 to \$8,290 for two additional members. Legal steps include amending local ordinances and establishing appointment procedures, with election cycle changes determined by state statute. The final election pattern will be a 4/3 split, consistent regardless of timing. Next steps depend on the council's chosen approach, involving drafting an ordinance, scheduling readings, and continued monitoring of our city's population.

---

**Recommended Motion:**  
Discussion only

# Council Size Options

Expanding from 5 to 7 Members

City of Granite Falls – March 4, 2026

## RCW 35A.13.010 Framework

- Under 2,500 population: 5 councilmembers
- 2,500+ population: 7 councilmembers (optional)
- 5,000+ population: 7 councilmembers (mandatory)
- New positions filled by appointment until next election

## Current Council Structure

- 5 councilmembers elected at-large
- 4-year staggered terms
- Election cycle alternates between 3 and 2 positions
- Council-manager form of government since 2009

# Decision Point: Two Options

## Option A

Expand now (voluntary increase before 5,000)

## Option B

Wait until population reaches 5,000 (mandatory)

## Option A: Expand Now (Pros)

- Proactive governance planning
- Broader representation and diverse perspectives
- Better committee structure and coverage

## Option A: Expand Now (Cons)

- Increased compensation costs (~\$6,908 - \$8,290/year for 2 members)
- More complex meeting interaction and deliberation
- Council dynamics may shift unexpectedly

## Option B: Wait Until 5,000 (Pros)

- Defers additional costs until population growth justifies
- Maintains current efficient council size
- Statutory trigger removes discretionary decision

## Option B: Wait Until 5,000 (Cons)

- Reactive rather than proactive approach
- Forced timeline when population threshold met
- Less flexibility in timing the transition

# Legal Requirements

- Ordinance 776-09 establishes 5-member council in GFMC 2.08
- Must amend GFMC 2.08.010 by ordinance
- Ordinance changes "five (5)" to "seven (7)" members
- Separate action appoints members to Positions 6 & 7

## Option A Timeline

- Draft ordinance amending GFMC 2.08.010
- Adopt ordinance increasing council size to 7
- Council appoints two members to Positions 6 & 7
- Nov 2027: One elected for 2-year, one for 4-year term

## Option A Next Steps

- Council discussion and decision on timing
- City staff drafts ordinance amending GFMC 2.08.010
- First and final reading, adoption of ordinance
- Establish appointment process and criteria for new positions

## Option B Timeline

- Monitor population via OFM annual estimates
- When 5,000 reached: draft and adopt ordinance
- Council appoints two members to new positions
- Next election: one 2-year term, one 4-year term

## Option B Next Steps

- Track OFM population estimates annually
- Pre-draft ordinance amending GFMC 2.08.010
- Prepare appointment procedures and criteria
- Monitor workload and capacity needs

## Election Cycle Impact

- Regardless of timing, final pattern will be 4/3 split
- Cannot permanently establish 2-3-2 rotation
- RCW 35A.13.010 requires
  - "In the event of an increase in the number of council offices, the city council shall, by majority vote, pursuant to RCW 35A.13.020, appoint two persons to serve in these offices until the next municipal general election, at which election one person shall be elected for a two-year term and one person shall be elected for a four-year term."
- Initial 2-year and 4-year terms are transitional only

# Budget Impact

## Annual Costs

Councilmember compensation, benefits, training, travel

# Questions & Discussion

City of Granite Falls



## CITY COUNCIL AGENDA BILL

**Subject:** 7.e.

**Originating Dept.:** City Manager

**Action Recommended:** Consideration to authorize the City Manager to appoint three members to the City of Granite Falls Salary Commission in accordance with the existing Salary Commission ordinance, subject to City Council confirmation, and to direct staff to support the Commission in completing a City Council compensation review and filing a salary schedule with the City Clerk by July 1, 2026.

**Approval(s):**

**Meeting Date:** March 4, 2026

**Date Submitted:**

**Exhibit(s):**

1. Salary Commission Review March 4 2026
2. Ordinance No. 1023-2022 - Adding a Salary Commission

---

**Budgeted Amount:** \$21,131

**BARS Code:** 511 60 10 00 Salaries - Council  
511 60 20 00 Benefits - Council

---

**Summary Statement:**

This presentation provides an overview of the City's Salary Commission, including its statutory role and current status, and requests direction to reactivate it in 2026 for reviewing Council compensation. The independent, citizen-led commission last met in 2022, but its terms have expired. Reactivating it will enable a data-driven equity review of pay levels, considering inflation and market benchmarks, with any approved salary schedule enacted after filing with the City Clerk.

---

**Background:**

This presentation reviews the authority granted by RCW 35.21.015 for cities to establish independent salary commissions to determine the pay of elected officials, with decisions taking effect automatically and allowing mid-term increases. In 2022, the City formed a three-member Salary Commission to review and recommend salaries, which are then automatically adopted unless challenged by referendum. Since then, the Commission has not been active, and the scheduled 2025 review was missed, leaving the current salary structure in place based on the 2022 review and inflation adjustments.

Currently, the Commission's inactivity has resulted in the expiration of its members' terms, preventing it from functioning until new members are appointed and confirmed. The 2026 Council compensation, based on the 2022 structure plus cost-of-living adjustments, is lower than that of comparable nearby cities, which typically offer higher monthly and annual pay. Rising costs of living, regional Consumer Price Index data, and inflation suggest that limited compensation may hinder the diversity of Council candidates, thereby affecting representation.

Reactivating the Commission in 2026 would restore an independent, citizen-led process, supported by staff in data gathering, analysis, and public coordination. The process would include member appointments in early 2026, deliberations mid-year, and the filing of a salary schedule by July 1. The fiscal impact of any proposed increases would be manageable within the City's budget, although supporting the Commission would require additional staff effort. Alternatively, the City can choose to keep the Commission inactive or amend the ordinance before reactivation, or set different expectations.

Staff recommends that the City Council authorize the City Manager to proceed with reactivating the Salary Commission in 2026. This includes nominating three qualified citizen members for Council confirmation, preparing and providing necessary data and analysis, and supporting the Commission in filing a salary schedule with the City Clerk by July 1, 2026.

---

**Recommended Motion:**

Move to authorize the City Manager to appoint three members to the City of Granite Falls Salary Commission in accordance with the existing Salary Commission ordinance, subject to City Council confirmation, and to direct staff to support the Commission in completing a City Council compensation review and filing a salary schedule with the City Clerk by July 1, 2026.

# Salary Commission Review

City Council Compensation Analysis

City of Granite Falls, Washington

March 4, 2026

## Why Have a Salary Commission?

- **State law requirement:** RCW 35.21.015 authorizes a citizen salary commission
- **Independent review:** Removes Council from setting own compensation
- **Transparency:** Public process with citizen participation
- **Regular review:** Addresses cost of living and market changes

## Granite Falls Current Ordinance (2022)

- **Three members:** Appointed by City Manager with Council approval
- **Two-year terms:** Staggered terms, unpaid service
- **Residency:** At least 2 residents; 1 may be business owner
- **Review schedule:** First in 2022, then every 3 years (2025, 2028...)

## Key Differences: Ordinance vs. RCW

Element	Current Ordinance	RCW Allows
Members	3 members	3 or more (often 5)
Term length	2 years	City determines
Appointing authority	City Manager	Often mayor
Review frequency	Every 3 years	At least every 4 years

## Current Commission Status

- **Last active:** 2022 (completed compensation review)
- **Next scheduled review:** 2025 per ordinance (overdue)
- **Current members:** Terms have expired; Commission needs reappointment
- **Action required:** City Manager must appoint new members with Council approval

## Reactivating the Commission

- **City Manager nominates:** 3 citizen members meeting ordinance qualifications
- **Council confirms:** Approves City Manager appointments
- **Staff support begins:** Coordinate meetings, provide research and data
- **Commission convenes:** Hold public meeting(s) and deliberate

# Commission Authority

- **Reviews salaries:** All elected officials
- **Files recommendation:** Written salary schedule with City Clerk by July 1
- **Automatic effectiveness:** Becomes law without Council action (unless rejected)
- **Current-term increases:** Salary increases effective immediately for all officials

# Current 2026 Compensation

2022 structure with COLA applied:

- **Typical month (2 meetings):** \$287.84/month
- **With work session (3 meetings):** \$345.41/month
- **Estimated annual:** \$3,454 - \$4,145

## Comparable City Council Salaries

City	Population	Monthly Pay	Annual Est.
Sultan	~5,300	\$350-400	\$4,200-4,800
Snohomish	~10,000	\$300-350	\$3,600-4,200
Monroe	~20,000	\$500-600	\$6,000-7,200
Granite Falls	~4,700	\$287-345	~\$3,454-4,145

## Cost of Living Since 2022

- **Seattle-area CPI (Dec 2025):** 3.1% annual inflation
- **Food costs:** Up 4.4% year-over-year
- **Energy costs:** Up 7.2% year-over-year
- **Cumulative 2022-2026:** ~12.5% inflation impact

# Equity and Accessibility

Lower compensation can create barriers:

- Limits candidate pool to those who can afford volunteer service
- May exclude working families, younger professionals, single parents
- Reduces diversity of perspectives and experiences

## Staff Support for Commission

- **Meeting coordination:** Schedule, notice, facilitate public meetings (OPMA compliance)
- **Research and data:** Comparable cities, current compensation, cost of living, budget impacts
- **Documentation:** Minutes, records, findings
- **Filing:** Submit recommendation to City Clerk

## Proposed Timeline

- **March-April 2026:** City Manager nominates members; Council confirms
- **April-May 2026:** Staff prepares research and data; Commission convenes
- **May-June 2026:** Public meeting(s), deliberation, develop recommendation
- **By July 1, 2026:** File salary schedule with City Clerk

## After Commission Files Recommendation

- **Automatic effectiveness:** Becomes law without Council vote
- **30-day referendum period:** Citizens may petition for referendum vote

## Effective Date Requirements

- **Salary increases:** Effective immediately for all officials, even during current terms
- **Salary decreases:** Cannot take effect until next term (State Constitution Article XI Section 8)
- **Key advantage:** Commission can approve mid-term increases (Council cannot when setting own pay)

## Next Steps: Council Action

- **Authorize City Manager:** Direct City Manager to appoint Salary Commission members
- **Council confirmation:** Approve City Manager appointments (March-April 2026)
- **Staff preparation:** Begin research, data collection, meeting coordination
- **Commission launch:** First meeting by May 2026

# Questions & Discussion

City Council

**ORDINANCE NO. 1023-2022**

**AN ORDINANCE OF THE CITY OF GRANITE FALLS AMENDING THE GRANITE FALLS MUNICIPAL CODE TO AMEND SECTION 2.08.030 AND ADD AN INDEPENDENT SALARY COMMISSION UNDER TITLE 2 – ADMINISTRATION AND PERSONNEL AS CHAPTER 2.58 – SALARY COMMISSION.**

**WHEREAS**, the Granite Falls Municipal Code 2.08.030 entitled “Compensation” provides for compensation and expense reimbursement of Council members; and

**WHEREAS**, the City Council wishes to create a salary commission to review and set the salaries of elected officials; and

**WHEREAS**, RCW 35.21.015 provides authority for cities to create salary commissions; and

**WHEREAS**, the Granite Falls Municipal Code needs to contain a process for the appointment and administration of a salary commission.

**NOW, THEREFORE, THE CITY COUNCIL OF THE CITY OF GRANITE FALLS DOES HEREBY ORDAIN AS FOLLOWS:**

**SECTION 1. – Title 2 Amended**

GFMC Section 2.08.030 entitled “Compensation” is hereby amended to read as follows:

**2.08.030 Compensation. Expenses.**

~~The council members shall be paid compensation in the amount of \$100.00 per month. Council members may be reimbursed for actual expenses incurred in the discharge of official duties upon presentation of a claim therefor and its allowance and approval by resolution of the council.~~  
Compensation shall be \$100 per month until increased or decreased by the Salary Commission established by Chapter 2.58 Granite Falls Municipal Code.

**SECTION 2. – Title 2 Amended**

There is hereby added a new Chapter 2.58 to the Granite Falls Municipal Code which shall have the title and sections listed in Exhibit A.

**SECTION 3. – Severability**

If any section, sentence, clause, or phrase of this Ordinance shall be held to be invalid or unconstitutional by a court of competent jurisdiction, such invalidity or unconstitutionality shall not affect the validity or constitutionality of any section, sentence, clause, or phrase of this Ordinance.

**SECTION 4. – Effective Date**

This ordinance or a summary thereof consisting of the title shall be published in the official newspaper of the City and shall take effect and be in full force five (5) days after publication.

Passed by the City Council of the City of Granite Falls this 16<sup>th</sup> day of March, 2022.

Approved by the Mayor of the City of Granite Falls this 16<sup>th</sup> day of March, 2022.

CITY OF GRANITE FALLS

  
\_\_\_\_\_  
Matthew Hartman, Mayor

ATTEST/AUTHENTICATED

  
\_\_\_\_\_  
Darla Reese, MMC, City Clerk

APPROVED AS TO FORM:

  
\_\_\_\_\_  
Thom Graafstra, City Attorney  
Emily Guildner, City Attorney

Passed by City Council: March 16, 2022

Date of Publication: March 23, 2022

Effective Date: March 28, 2022

**TITLE 2  
ADMINISTRATION AND PERSONNEL**

**Chapter 2.58 – SALARY COMMISSION**

**Sections:**

- 2.58.005 Purpose.
- 2.58.010 Created – Membership, appointment, compensation, term.
- 2.58.020 Vacancies.
- 2.58.030 Removal.
- 2.58.040 Duties.
- 2.58.050 Referendum.

**2.58.005 Purpose.**

The purpose of this chapter is to utilize RCW 35.21.015 which authorizes the city to establish through ordinance an independent salary commission given authority to set the salary of the members of City Council and of other elected city officials, and provides that the commission's action fixing such salaries shall supersede any provision in a city ordinance related to fixing salaries.

**2.58.010 Created – Membership, appointment, compensation, term.**

- (1) There is created a salary commission for the city. The commission shall consist of three members, to be appointed by the city manager with the approval of the city council.
- (2) Not less than two shall be residents of Granite Falls, the other one may be owners of business located within the city.
- (3) A member of the commission shall serve for a two-year term without compensation. The initial members shall be appointed for staggered terms.
- (4) Two members of such commission shall constitute a quorum and the vote of any three members of such commission concurring shall be sufficient for the decisions of all matters and the transaction of all business.
- (5) A member of the commission shall not be an officer, official, or employee of the city or an immediate family member of an officer, official, or employee of the city. For purposes of this section, "immediate family members" means the parents, spouse, siblings, children, or dependent relatives of an officer, official, or employee of the city, whether or not living in the household of the officer, official, or employee.

**2.58.020 Vacancies.**

In the event of a vacant spot in office of commissioner, the city manager shall appoint, subject to the city council's approval, a person to serve the unexpired portion of the term of the expired position.

**2.58.030 Removal.**

A member of the commission shall only be removed from office for cause of incapacity,

incompetence, neglect of duty, or malfeasance in office, or for a disqualifying change of residence.

**2.58.040 Duties.**

(1) The independent salary commission shall have the duty, at such intervals as determined by the commission, to review the salaries paid by the city to each elected city official. Such review shall occur first in 2022, and no less frequently than every third year thereafter commencing in 2025. If after such review the commission determines that the salary of any elected official should be increased or decreased, the commission shall file a written salary schedule with the city clerk indicating the increase or decrease in salary. The commission's action shall be taken by July 1 of the review year.

(2) Any increase or decrease in salary established by the commission shall become effective and incorporated into the city budget without further action of the city council or the commission.

(3) Salary increases established by the commission shall be effective as to all city elected officials, regardless of their terms of office.

(4) Salary decreases established by the commission shall become effective as to incumbent city elected officials at the commencement of their next subsequent terms of office. Article XI Section 8 of the State Constitution prohibits salary decreases during the current term.

**2.58.050 Referendum.**

Any salary increase or decreases established by the independent salary commission pursuant to this chapter shall be subject to referendum petition by voters of the city, in the same manner as a city ordinance, upon filing of a referendum petition with the city clerk within 30 days after filing of a salary schedule by the commission. In the event of the filing of a valid referendum petition, the salary increase or decrease shall not go into effect until approved by a vote of the people. Referendum measures under this section shall be submitted to the voters of the city at the next following general or municipal election occurring 30 or more days after the petition is filed, and shall otherwise be governed by the provisions of the State Constitution and the laws generally applicable to referendum measures.



## CITY COUNCIL AGENDA BILL

**Subject:** 7.f.

**Originating Dept.:** City Manager

**Action Recommended:** Discussion Only    **Approval(s):**

**Meeting Date:** March 4, 2026

**Date Submitted:**

**Exhibit(s):**

1. Legion\_Park\_Presentation

---

**Budgeted Amount:** \$200,000

**BARS Code:** 594 73 60 01

---

### **Summary Statement:**

The purpose of this agenda item is to present the City Council with conceptual park layouts, monument design options, and supporting feature alternatives for the proposed Legion Park – a veterans memorial and community gathering space. Following the Council's direction at the summer 2025 retreat to develop conceptual plans, staff have prepared three site layout options, three monument design concepts shaped after Mount Pilchuck, amphitheater/pavilion alternatives, restroom facility options, shelter structures, lighting, and historical flag display concepts for Council review and discussion.

Council direction is needed so that staff can proceed with public outreach on the preferred concepts and place the monument order with the manufacturer in time for installation before July 4, 2026. A ribbon-cutting ceremony and community 5-K fun run are tentatively planned for the grand opening.

---

### **Background:**

At the City Council's summer 2025 retreat, Council directed staff to develop conceptual layouts for the proposed Legion Park. The park is envisioned as a dual-purpose space: a veterans memorial honoring those who served and a community gathering place for residents and visitors. The centerpiece of the park is a monument designed in the

shape of Mount Pilchuck, positioned so the actual mountain is clearly visible behind it. The monument will incorporate surfaces for all six U.S. Armed Forces branch seals (Army, Navy, Air Force, Marines, Coast Guard, and Space Force), veteran tributes, and commemorative text.

Legion Park outdoor plaza funding was identified as a priority item on the City's 2026 Legislative Agenda, as discussed at the November 19, 2025 Council meeting. Regional examples of veterans memorials – including those in Lake Stevens (dedicated July 4, 2020; estimated cost \$150,000–\$300,000), Auburn (dedicated 2007; \$200,000–\$400,000), Enumclaw (dedicated July 4, 2009; \$200,000–\$400,000), and Anacortes (dedicated 2016; \$200,000–\$400,000) – were reviewed to inform the design direction and scope of the Granite Falls project.

### Park Layout Options

Staff has developed three conceptual site layouts for Council consideration. All three options include the Mount Pilchuck veterans monument as the centerpiece, an amphitheater, a train feature, a food court area, and US flag lighting throughout the park:

- Layout Option A: Memorial Wall, Amphitheater, Train, Food Court, Restrooms, Vendor Area (on-site), and US Flag Lighting.
- Layout Option B: Memorial Wall, Amphitheater, Train, Food Court, Vendors Across Street, and US Flag Lighting. No on-site restrooms.
- Layout Option C: Memorial Wall, Amphitheater, Train, Food Court, Restrooms, Vendors Across Street, and US Flag Lighting.

### Monument Design Options

The monument is designed in the shape of Mount Pilchuck, with the actual mountain visible behind the placement. Three design variations are presented:

- Option 1 – Open Frame: Features an open frame at the top that allows the actual mountain to be seen through the monument.
- Option 2 – Asymmetric Profile: An asymmetric mountain profile design.
- Option 3 – Solid Mountain: A solid mountain silhouette design.

3D renderings showing each monument option from multiple perspectives (front elevation, aerial views, and rear elevation) are included in the attached presentation.

### Amphitheater / Pavilion Options

- Option A – Traditional Pavilion: Open timber frame design with stone base and covered stage area.
- Option B – Modern Steel Pergola: Contemporary steel structure (CWC 15x700) with open-air design.
- Option C – Curved Wood Modern: Modern curved timber and wood slat design with covered walkway.

### Additional Park Features

The presentation also includes options for Council review in the following categories:

- Shelter and shade structures (Poligon powder-coated steel frames with PCI-4000

certified finish), including farmers market, amphitheater, and pavilion configurations.

- Restroom facility options ranging from compact restrooms (no storage) to brick and masonry or modern panel facilities with storage.
- Park pathway lighting using modern LED bollard lights for ambient illumination, safety, and evening aesthetics.
- Historical US flag displays with lighting, creating a patriotic walkway showcasing the evolution of the nation's flag from the Continental Union to the current 50-star design.
- Service branch recognition incorporating seals for all six branches of the United States Armed Forces.

#### Next Steps

Upon receiving Council direction, staff will proceed with the following timeline:

1. Council provides direction on preferred layout, monument design, and park features.
2. Staff conducts public outreach to gather community input on the selected concepts.
3. Upon Council agreement on monument design, staff places the order with the manufacturer for fabrication.
4. Manufacturer installs the monument ahead of the July 4, 2026 target date.
5. Grand opening celebration with ribbon cutting and community 5-K fun run.

---

#### **Recommended Motion:**

Discussion only

CITY OF GRANITE FALLS, WASHINGTON

# Legion Park

Proposed Park Layouts & Feature Options

**City Council Work Session**

February 2026

Staff Presentation for Council Review & Direction



Honoring Those Who Served | A Community Gathering Place

# Purpose & Background

## Council Direction

Following the Council's summertime retreat, staff was directed to develop conceptual layouts for the proposed Legion Park.

The park will serve as a veterans memorial and community gathering space, with the centerpiece monument designed in the shape of Mount Pilchuck, positioned so the actual mountain is clearly visible behind it.

This presentation provides layout and feature options for Council to review, discuss, and provide direction. Staff will then conduct public outreach to gather community input.

**Goal:** Council agrees on the monument design so staff can place the order for manufacturer installation before July 4th. A ribbon cutting and 5-K fun run are tentatively planned.



# Layout Option A

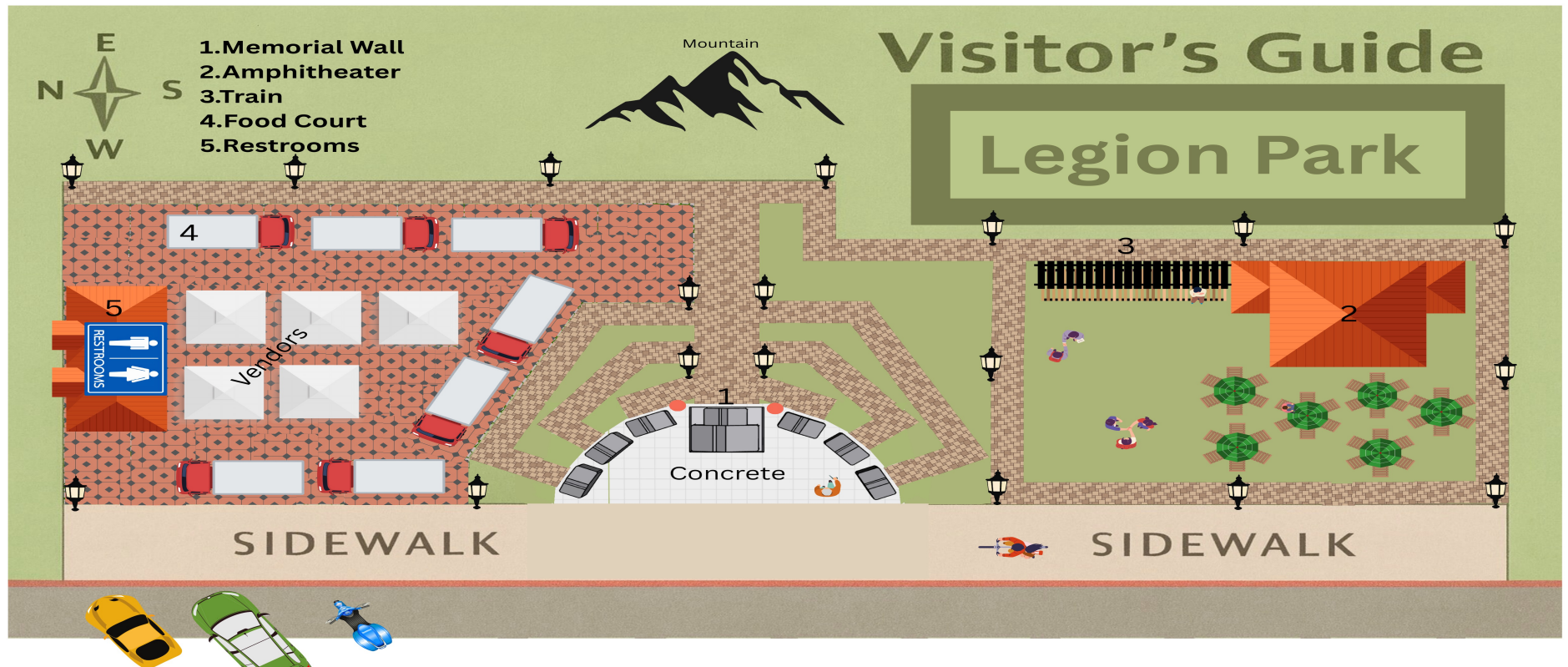

**Features:** Memorial Wall | Amphitheater | Train | Food Court | Restrooms | Vendor Area | US Flag Lighting

# Layout Option B

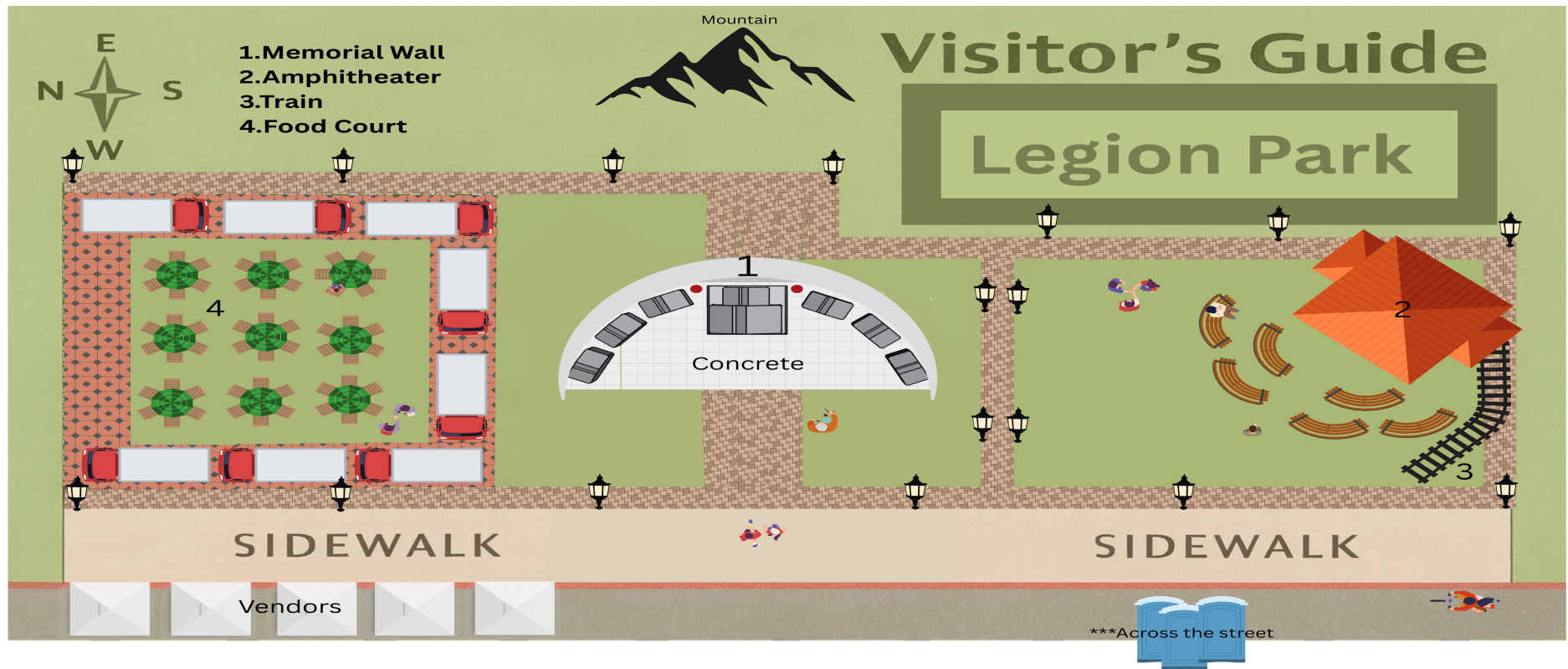

Features: Memorial Wall | Amphitheater | Train | Food Court | Vendors Across Street | US Flag Lighting

# Layout Option C

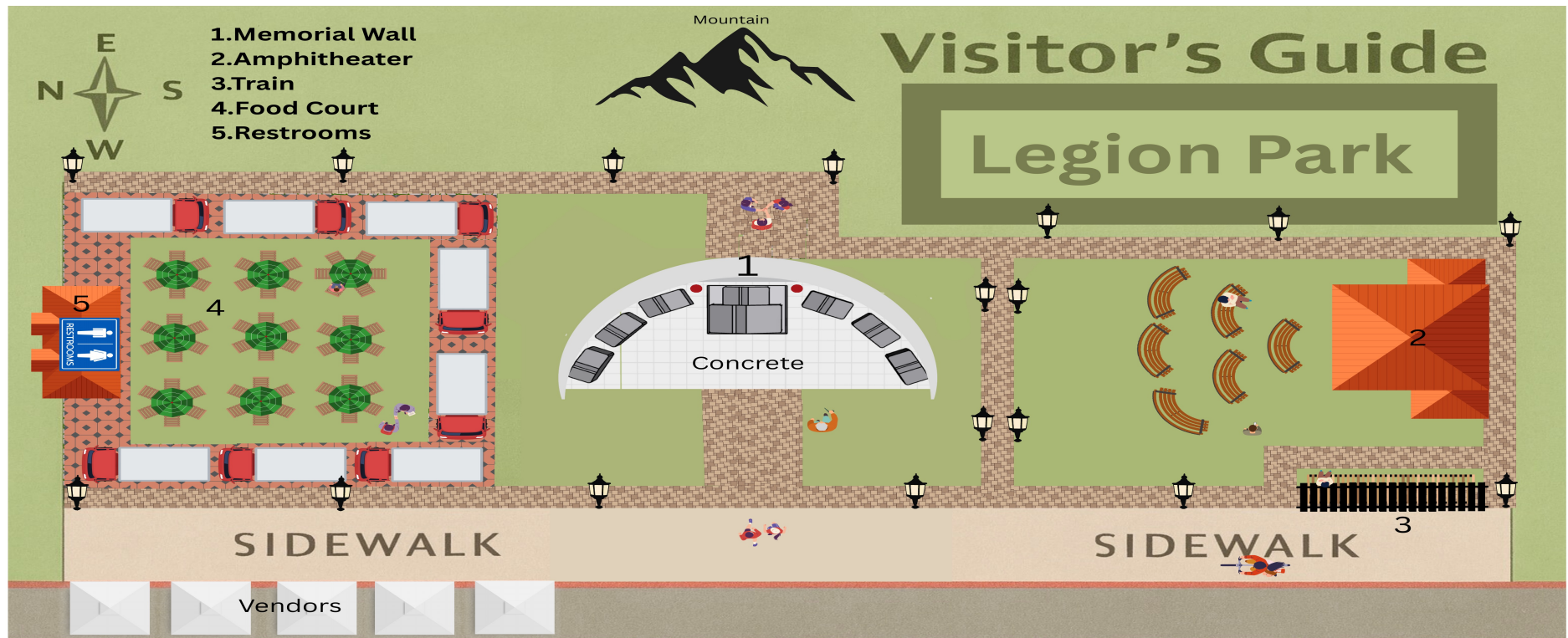

Features: Memorial Wall | Amphitheater | Train | Food Court | Restrooms | Vendors Across Street | US Flag Lighting

# Monument Design - Mount Pilchuck Shape

The monument is designed in the shape of Mount Pilchuck with the actual mountain visible behind the placement. The open frame at top allows the mountain to be seen through the monument.

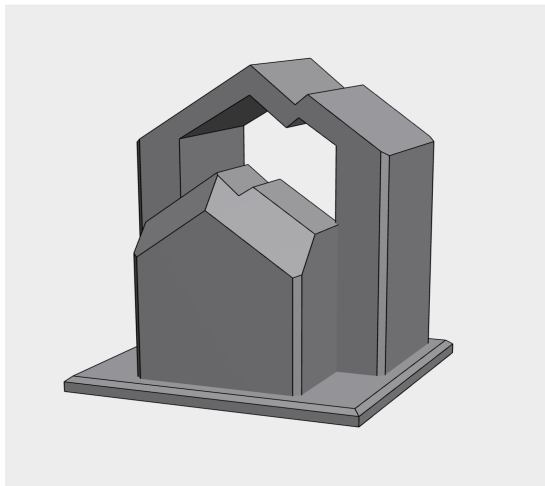

**Option 1 - Open Frame**

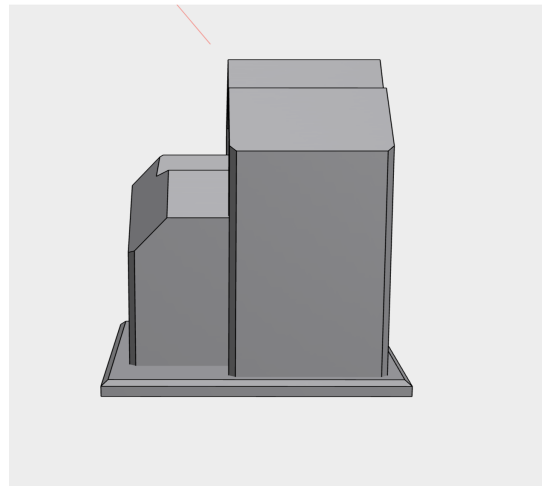

**Option 2 - Asymmetric Profile**

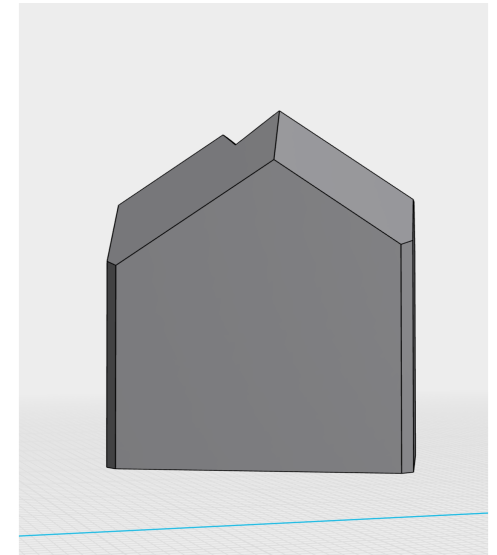

**Option 3 - Solid Mountain**

# Monument Design - Additional Views

3D renderings showing the monument from multiple perspectives. The design incorporates surfaces for service branch seals, veteran tributes, and commemorative text.

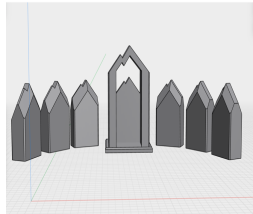

Front Elevation

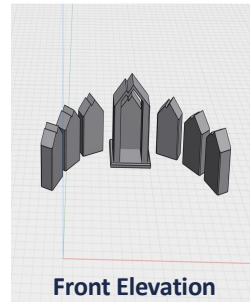

Front Elevation

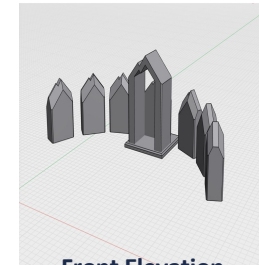

Front Elevation

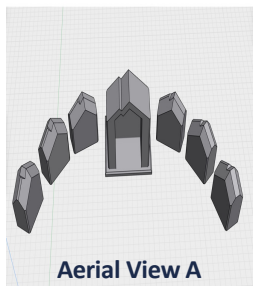

Aerial View A

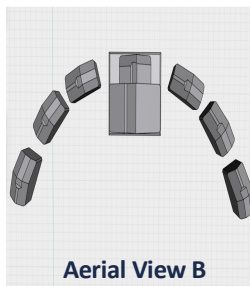

Aerial View B



Rear Elevation

# Lake Stevens War Veterans Memorial

## *Regional Inspiration*

Dedicated July 4, 2020

Estimated Cost: \$150,000 - \$300,000

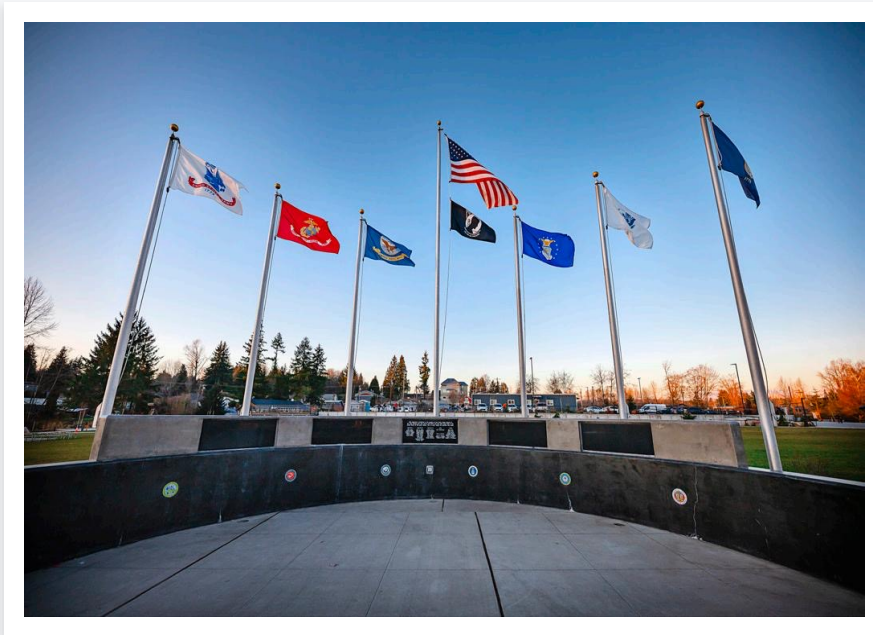

# Auburn Veterans Memorial Park

## *Regional Inspiration*

**Dedicated 2007**

Estimated Cost: \$200,000 - \$400,000



# Enumclaw Veterans Monument

## *Regional Inspiration*

Dedicated July 4, 2009

Estimated Cost: \$200,000 - \$400,000



# Anacortes Veterans Monument

## Regional Inspiration

Dedicated 2016

Estimated Cost: \$200,000 - \$400,000

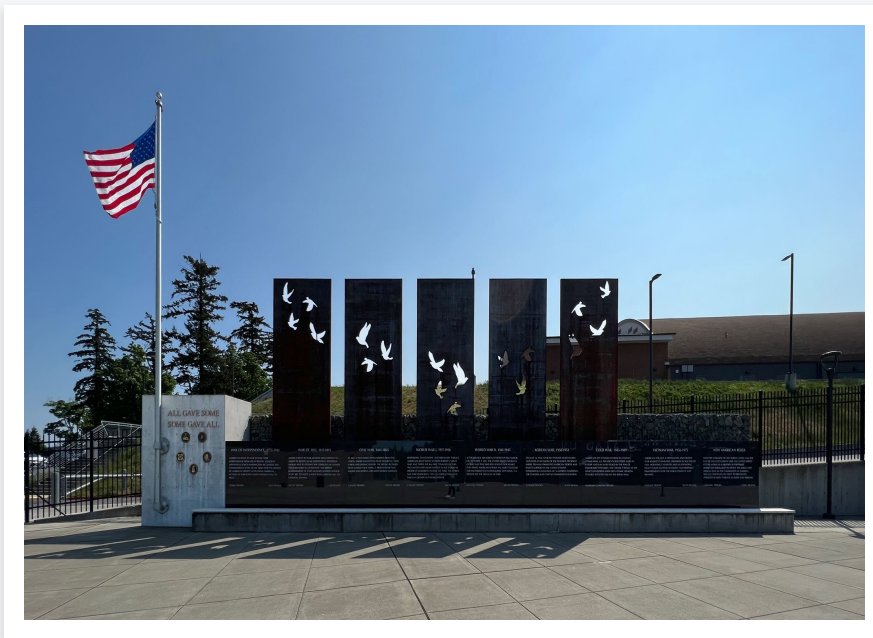

# Additional Veterans Monument Samples

Examples of veterans monuments from communities across the country, showcasing various design approaches including stone walls, bronze sculptures, flag displays, and memorial seating areas.



# More Veterans Monument Samples

Further examples highlighting modern memorial design elements such as illuminated pillars, granite walls with etched imagery, star-shaped layouts, and integrated service branch seals.



# Amphitheater & Pavilion Options



## Option A - Traditional Pavilion

Open timber frame design with stone base and covered stage area



CWC15x700 - 55390

## Option B - Modern Steel Pergola

Contemporary steel structure (CWC 15x700) with open-air design

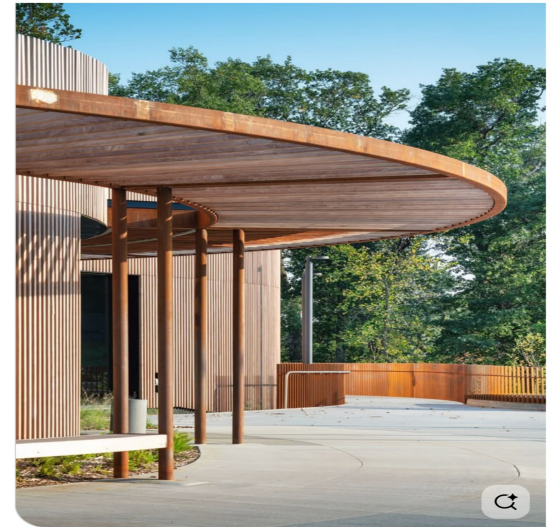

## Option C - Curved Wood Modern

Modern curved timber and wood slat design with covered walkway

# Shelter & Shade Structures

Poligon shelter structures offer powder-coated steel frames with PCI-4000 certified finish for long-term durability.

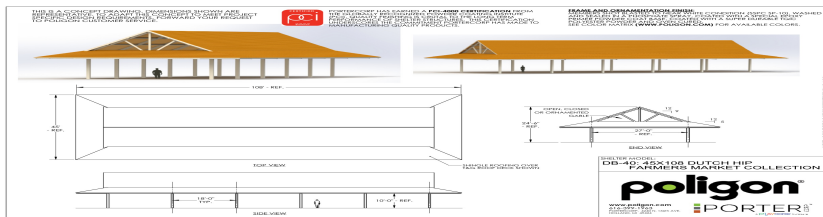

**DB-40: 45'x108' Dutch Hip (Farmers Market)**

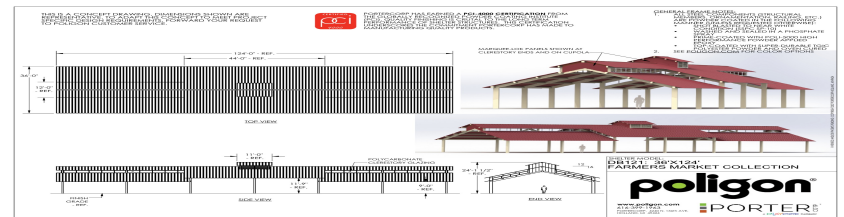

**DB-121: 36'x124' Farmers Market w/ Clerestory**

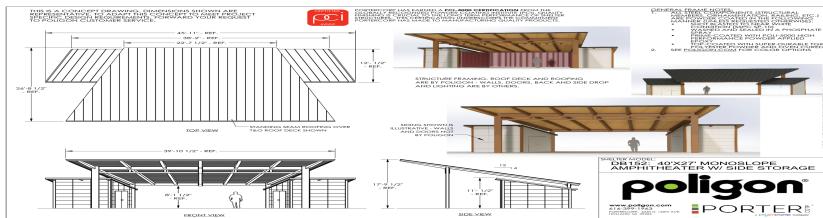

**DB-152: 40'x27' Monoslope Amphitheater w/ Storage**

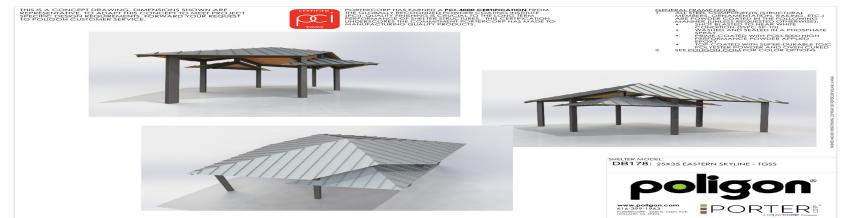

**DB-178: 25'x35' Eastern Skyline Pavilion**

# Restroom Facility Options



**Option 1**  
Compact  
Restroom  
No Storage



**Option 2**  
Timber Frame  
With Storage



**Option 3**  
Brick & Masonry  
With Storage



**Option 4**  
Modern Panel  
With Storage

# Park Lighting

## Park Pathway Lighting

Modern LED bollard lights provide ambient illumination for pathways and flag displays, enhancing safety and evening aesthetics throughout the park.



# US Flags

## Historical US Flags

Various historical US flags can be installed throughout the park with lighting, creating a patriotic walkway showcasing the evolution of our nation's flag from the Continental Union to the current 50-star design.

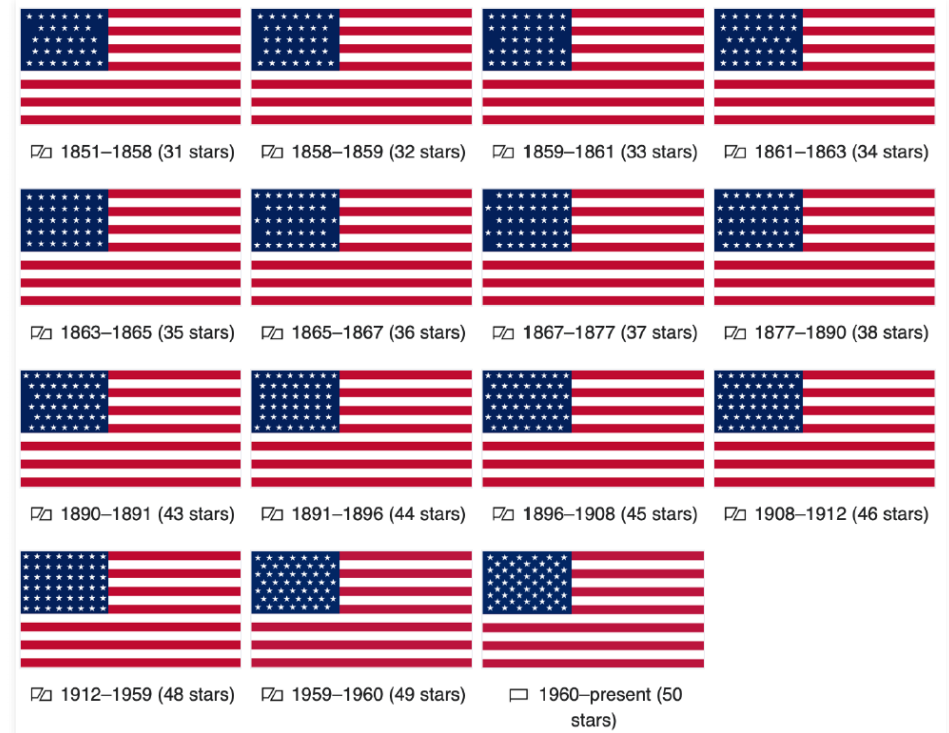

# Service Branch Recognition

The monument and surrounding park will honor all six branches of the United States Armed Forces. Service branch seals will be incorporated into the monument design.



Air Force | Marines | Army | Space Force | Navy | Coast Guard

# Next Steps & Timeline

1

## Council Provides Direction

Council reviews layout options and features, selects preferred monument design and park elements

---

2

## Public Outreach

Staff conducts community outreach to gather public input on selected layouts and features

---

3

## Monument Order

Upon Council agreement, staff places the order with the manufacturer for monument fabrication

---

4

## Monument Installation

Manufacturer installs the monument ahead of the July 4th target date

---

5

## Ribbon Cutting & 5-K Fun Run

Grand opening celebration with ribbon cutting and a community 5-K fun run at the park

# Discussion & Direction

---

## Key Questions for Council

- Which park layout does Council prefer?
- Which monument design should staff order?
- Which amphitheater/pavilion style is preferred?
- Which restroom option best serves the park?
- What other features or modifications are desired?